



# Operating instructions and Technical manual **Olympia Care**



Version : G 30/01/2017

---

IMPORTANT : KEEP FOR FUTURE REFERENCE : READ CAREFULLY

# ACTIVATION: SUMMARY

## Olympia Care

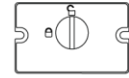

Manipulation	Hand switch	Hand switch HD	Satellite control FPP	Mini-nurse box ACC	Lock box ACL
<b>BACKREST</b> 					
<b>KNEEREST</b> 					
<b>RELAXPOSITION</b> 					
<b>HIGH/LOW</b> 					
<b>SLEEPING POSITION</b> 					Not active when a function has been locked
<b>ANTI-TREND.</b> 					
<b>Emergency operations</b>					
<b>TREND.</b> 					
<b>CPR</b> 					Irrespective of any blocked functions.
<b>Lock/Unlock</b>					
<b>Nightlight under the bed on/off</b>					

# Olympia Care

## Quick release

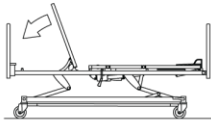

## Lever

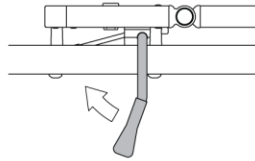

## Bed extension

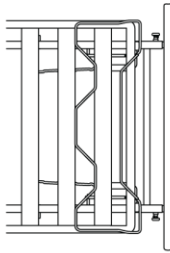

1. lift the footrest
2. pull out both pull knobs
3. pull out the bed extension
4. lock the buttons
5. pull out the foot extension (option)

## Central brake mechanism

### 1 directional castor, fixed

### 4 castors unbraked

### 4 castors braked

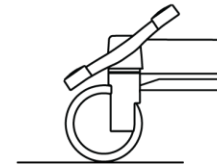
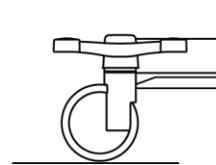
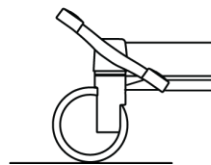
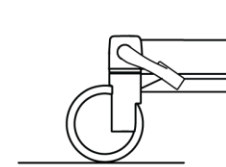
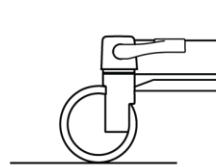
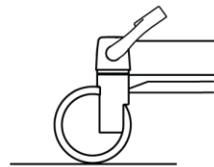

The available bed functionality is in line with the chosen and ordered configuration.

# PREFACE

Dear user,

Haelvoet would like to thank you for the confidence you have put in our company by opting for a Haelvoet product. You have chosen a high-end product resulting from our inexhaustible experience in the development and production of hospital beds. Our continuous pursuit of improvement and optimisation aims at increasing our customer satisfaction even more. All our products are fully checked before they leave our company. If you face a problem, however, please do not hesitate to contact us.

This manual has been written to make you familiar with the installation, the electric and mechanical aspects, and the maintenance of this Haelvoet product. Therefore, we strongly advise you to go through this document before using or servicing the product. Please do not hesitate to ask for extra manuals at Haelvoet NV in case this may seem necessary. We kindly request you to make sure that all users and maintenance technicians have the necessary information at their disposal and have access to it at all times.

The purpose of this manual is to offer you a clear and transparent overview of the functional and technological aspects of the bed. Consequently, Haelvoet NV cannot be held liable for any damage or injuries that result from incorrect product usage, incorrect bed interventions or any possible unclear descriptions in this document. Since Haelvoet NV continually aims at making technological progress, Haelvoet reserves the right to modify the product as well as this manual, and all this without prior notice.

Nothing from this edition may be multiplied and/or made public in any form or manner, either mechanically or electronically, without prior written consent of Haelvoet NV.

# TABLE OF CONTENTS

<b>ACTIVATION: SUMMARY</b> .....	<b>2</b>
<b>PREFACE</b> .....	<b>4</b>
<b>TABLE OF CONTENTS</b> .....	<b>5</b>
<b>LIST OF FIGURES</b> .....	<b>8</b>
<b>I. SAFETY INSTRUCTIONS</b> .....	<b>10</b>
1.1 General instructions.....	10
1.2 Moving sections.....	13
1.3 Sideguards .....	14
1.4 Bed/foot extension.....	14
1.5 Preventive maintenance .....	15
1.6 Mains cable .....	15
1.7 Battery (optional) .....	15
1.8 Spare parts and options .....	15
1.9 Alarm signals.....	15
1.10 Applied parts.....	16
<b>II. OPERATING INSTRUCTIONS</b> .....	<b>17</b>
2.1 Electric functions .....	17
2.1.1 Electric function possibilities.....	19
2.1.2 Extra nursing functionalities on the hand switch HD with magnet key (optional).....	22
2.1.3 Blocking of the electric functions (options) .....	23
2.1.4 Battery (optional) .....	24
2.1.5 Illuminated hand switch (option) .....	24
2.1.6 Nightlight under the bed (option) .....	24
2.1.7 Reset Procedure.....	24
2.2 Mechanical functions.....	26
2.2.1 CPR: manual (optional) .....	26
2.2.2 Leg- and footrest adjustment: manual .....	26
2.2.3 Mattress platform .....	27
2.2.4 Separate brake .....	27
2.2.5 Central brake .....	28
2.2.6 Moving the bed .....	29
2.2.7 Telescopic bed and footrest extension (option).....	30
<b>III. POSSIBLE OPTIONS</b> .....	<b>32</b>

3.1 Sideguards .....	33
3.1.1 Type Atmosphere .....	33
3.1.2 Type Atmosphere heightened (option) .....	34
3.1.3 Type Pollux .....	34
3.1.4 Type Pollux extended .....	35
3.1.5 Type Trix .....	37
3.2 Lifting pole .....	39
3.3 IV rod .....	40
3.4 IV holder for the lifting pole.....	40
3.5 Flexible hand switch holder .....	41
3.6 Patient restraint straps.....	41
3.7 Accessory hooks .....	41
<b>IV. CLEANING AND DISINFECTION OF THE BED .....</b>	<b>42</b>
4.1 General information .....	42
4.2 Degree of protection of the bed: IPX4 .....	43
4.2.1 Cleaning.....	43
4.2.2 Disinfection .....	43
<b>TECHNICAL MANUAL .....</b>	<b>44</b>
<b>V. GENERAL TECHNICAL DESCRIPTION.....</b>	<b>45</b>
<b>VI. ELECTRIC TECHNICAL DATA .....</b>	<b>49</b>
6.1 Control box .....	49
6.2 Hand switch .....	49
6.3 Hand switch HD.....	49
6.4 Satellite control .....	49
6.5 Control panel .....	50
6.6 Battery .....	50
6.7 Backrest actuator.....	50
6.8 Knee rest actuator .....	50
6.9 High-low actuators.....	51
6.10 Ambient conditions for the actuators .....	51
6.11 General specifications of the CB 06 control box .....	52
6.12 Precautions for cable connections .....	52
<b>VII. MECHANICAL TECHNICAL DATA .....</b>	<b>53</b>

<b>VIII. TECHNICAL DATA CASTORS.....</b>	<b>53</b>
<b>IX. STORAGE OF THE BED.....</b>	<b>54</b>
<b>X. PREVENTIVE AND CURATIVE MAINTENANCE .....</b>	<b>55</b>
10.1 Safety responsibility.....	55
10.2 Preventive maintenance Trix and Pollux .....	56
10.3 Spare parts .....	57
10.4 Used fastening methods.....	58
10.5 Replacement of a high/low actuator .....	58
10.6 Replacement of a mattress platform actuator .....	59
10.7 Readjustment of the CPR lever (optional).....	59
10.8 Battery (optional) .....	60
10.9 Replacement of the mains cable .....	61
10.10 Replacement of a control box.....	62
<b>XI. POSSIBLE PROBLEMS.....</b>	<b>63</b>
<b>XII. ACCESSORIES .....</b>	<b>64</b>
<b>XIII. GUARANTEE .....</b>	<b>65</b>
<b>XIV. RESIDUAL WASTE AND THE ENVIRONMENT .....</b>	<b>66</b>
<b>XV. SYMBOLS .....</b>	<b>68</b>
<b>XVI. CONFORMITY.....</b>	<b>69</b>
16.1 Explanation CE-label and Identification-label.....	69
16.2 Used symbols .....	70
<b>APPENDIX 1: EC-DECLARATION .....</b>	<b>72</b>
<b>APPENDIX 2: CHECKLIST MAINTENANCE.....</b>	<b>73</b>
<b>APPENDIX 3: EMC-TABLES .....</b>	<b>75</b>
<b>APPENDIX 4: TRAINING CERTIFICATE.....</b>	<b>79</b>

# LIST OF FIGURES

- Figure 1.1: Physical description of an adult patient ..... 10
- Figure 1.2: Bariatric graph ..... 11
- Figure 1.3: Applied parts ..... 16
- Figure 2.1: Hand switch ..... 17
- Figure 2.2: Mini nurse box ACC (optional) ..... 17
- Figure 2.3: Hand switch with magnet key (optional) ..... 17
- Figure 2.4: Lock box ACL (optional) ..... 17
- Figure 2.5: Satellite control FPP (optional) ..... 18
- Figure 2.6: High/Low foot pedal (optional) ..... 18
- Figure 2.7: Depiction of the electric HL-adjustment ..... 20
- Figure 2.8: Extra functionalities on hand switch HD with magnet key ..... 22
- Figure 2.9: Blocking of the electric functions on the lock box ..... 23
- Figure 2.10: Blocking of the electric functions ..... 23
- Figure 2.11: Nightlight under the bed ..... 24
- Figure 2.12: Reset procedure ..... 25
- Figure 2.13: CPR-lever ..... 26
- Figure 2.14: Legrest ..... 26
- Figure 2.15: Footrest ..... 27
- Figure 2.16: Removable mattress platform sections ..... 27
- Figure 2.17: Separate brakes ..... 27
- Figure 2.18: 4 activated castor brakes ..... 28
- Figure 2.19: 4 castor brakes, non-activated ..... 28
- Figure 2.20: One directional castor ..... 28
- Figure 2.21: Suspension hooks for the mains cable ..... 29
- Figure 2.22: Access to the bed extension ..... 30
- Figure 2.23: How to extend the bed ..... 30
- Figure 2.24: Extension of the foot end (option) ..... 31
- Figure 3.1: Sideguards Atmosphere: dimensions ..... 33
- Figure 3.2: Manipulation of the sideguards type Atmosphere ..... 34
- Figure 3.3: Sideguards Atmosphere heightened: dimensions ..... 34
- Figure 3.4: Sideguards Pollux: dimensions ..... 34
- Figure 3.5: Manipulation of the sideguards type Pollux ..... 35
- Figure 3.6: How to remove Pollux sideguards with a locking clip for Midea panel ..... 35
- Figure 3.7: How to install Pollux step 1 ..... 36
- Figure 3.8: How to install Pollux step 2 ..... 36
- Figure 3.9: How to install Pollux step 3 ..... 36
- Figure 3.10: How to install Pollux step 4 ..... 37
- Figure 3.11: Sideguards Trix: dimensions ..... 37
- Figure 3.12: Manipulation of the Trix sideguards ..... 38
- Figure 3.13: Exterior limits of the lifting pole ..... 39



Figure 3.14: Adjustment of an IV rod .....	40
Figure 3.15: IV holder on the lifting pole .....	40
Figure 3.16: Installation of the flexible hand switch holder .....	41
Figure 3.17: Accessory hooks .....	41
Figure 5.1: Mattress platform dimensions Olympia Care bed (standard width) .....	46
Figure 5.2: Mattress platform dimensions Olympia Care bed (width 90 cm) .....	46
Figure 5.3: Dimensions of the Olympia Care bed (standard width) .....	47
Figure 5.4: Dimensions of the Olympia Care bed (width 90 cm).....	47
Figure 5.5: Most important manipulation data of the Olympia Care bed.....	48
Figure 6.1: Circuit diagram Olympia Care .....	51
Figure 10.1: Greasing sideguards Trix and Pollux.....	56
Figure 10.2: Maintenance sideguards Trix(1) .....	56
Figure 10.3: Maintenance sideguards Trix(2) .....	56
Figure 10.4: Maintenance sideguards Trix(3) .....	57
Figure 10.5: Axle and axle retaining ring .....	58
Figure 10.6: Cable clamp .....	58
Figure 10.7: Quick release mechanism .....	59
Figure 10.8: Release of the strain relief type 1 .....	61
Figure 10.9: Release of the strain relief type 2 .....	61
Figure 10.10: Replacement of the mains cable in the control box .....	62
Figure 10.12: How to replace the control box .....	62

# I. SAFETY INSTRUCTIONS

## 1.1 General instructions



We strongly advise you again to read the entire manual, so that the instructions for an optimal use as well as those for a preventive and curative bed maintenance are carefully followed. The bed should be installed, maintained and used in accordance with this manual. Please inform all readers about the possible risks that can be run when not reading or following this manual.

The manufacturer, installer, importer or distributor of this product can only be held liable and stand surety for the basic safety, reliability and required qualities of the product if:

- decently trained technicians perform assembly tasks (e.g. assembly of accessories), adjustments, modifications, repairs and/or maintenance work.
- the bed is connected to electric installations that meet the requirements of the bed.
- the bed is used and maintained in accordance with the instructions in this manual and in a way that is considered a normal use of a nursing bed.
- the user, patient and technician have become acquainted with this manual and/or have received a good training of a qualified person.

By doing so, the risks for both the nursing staff and the patient are reduced considerably, whereas the product life of the bed is increased. At all times, the reader of this manual should be aware of the fact that this is an electric bed, and that the nursing staff and patient should be informed of the risks involved. Furthermore, all bed functions should be checked annually. Haelvoet NV even recommends that the bed is checked every six months, so that the safety of the patient is guaranteed even more.

The nursing bed is intended and made to treat, guard, alleviate or compensate diseases, injuries or handicaps of an **adult**.

The bed is not developed for people smaller than 146 cm, having a mass less than 40kg and having a body mass index (BMI) less than 17.

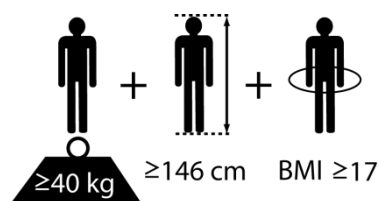

**Figure 1.1: Physical description of an adult patient**

Appropriate precautions have to be taken to treat small or very fragile patients. Small children have to be put in a cot or child's bed. Furthermore, it is very dangerous for children to operate the bed or to use it as a toy.

The Olympia Care bed can be used in application environments 3 and 5, as defined in IEC 60601-2-52:2009.

The maximum safe working load of the Olympia Care bed was stipulated to 230 kg. After deduction of the weight of accessories (15 kg) and mattress (20 kg), you become a maximum safe patient weight of 195 kg.

Based on the graph here below, we consider the Olympia bed with a safe patient weight of 195 kg, a bed that is suitable for bariatric patients.

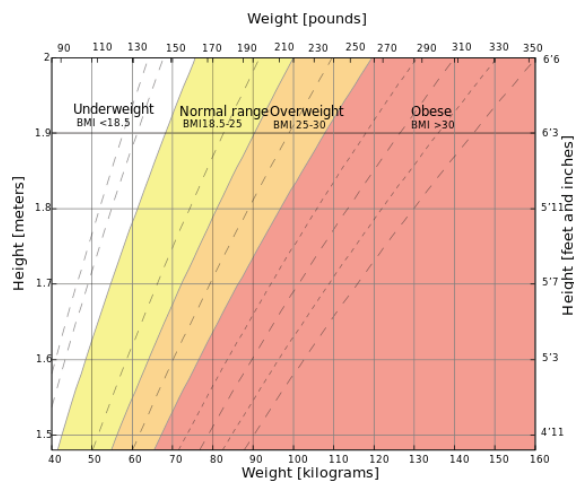

**Figure 1.2: Bariatric graph**

Please inform every user about the possible risks when the bed is used incorrectly, especially when the actuators and the sideguards have to be used.

Before you start using the bed, please make sure that the bed functions properly. That is why you have to check the following elements *before* you use it:

- Remove all packing material and recycle it environment-friendly.
- Please check if the bed and all its parts have been delivered in accordance with the delivery note.
- Please check if the bed has not been damaged during transport and delivery.
- In case huge temperature differences have to be overcome: let the bed adapt itself to the room temperature for 24 hours before using it and connecting it to the net.
- Read the entire manual.
- Clean the bed as described in chapter 4 of this manual.
- Make sure that the brakes of the bed have been activated.
- Please check if the power cable and the bed are compatible with the mains current of the room.
- Please check if the power cable, actuator cables and hand switch cable have not been damaged. Make sure that they have been installed in such a way that they cannot be damaged.
- Make sure that no obstacles hinder the free movement of the bed.
- Put the mattress, blankets and/or sheets on the bed, and make sure that they don't hinder the fluent operation of levers, the sideguards and the CPR lever.
- Check the bed functionality by means of the check list. (see appendix)
- Connect the bed only to a correctly installed socket in the vicinity of the bed.



Only use electric appliances that function perfectly in the vicinity of the bed. Make sure that these appliances are never connected by means of a multi-socket under the bed (risk of electrocution and fire because of the fluids). You should avoid using extension cords and multi-sockets.

This bed complies with the 93/42/EEC directive about medical devices and is categorized as a class I product. Keep in mind that every technical product, whether it is mechanical or electric, can be dangerous when it is used incorrectly. You should give priority to the interest and safety of the patient, visitor and manipulator at all times. Make sure that all users have access to this manual.

It is the responsibility of the distributor to inform the customer about the bed's functionality, maintenance and disinfection. The customer has to contact the distributor in case of uncertainties or insufficient user information. He also has to address himself to the distributor if he wants additional training.

Persons (playing children in particular) or obstacles may never be under the bed. Please make sure that all other equipment is put in safe conditions, before the bed is lowered, raised or removed. Take also care of the patient's safety during any bed manipulation. No bed function may be activated if there are obstacles of any kind in the vicinity of the bed.

Sitting on the bed is not allowed for people other than the patient.

Please make sure that the patient is put in the bed in the correct position. His head should be placed at the head end, whereas his feet should be at the bed's foot end.

Load the bed and its actuators only to the extent as described in the technical file. Always contact the technical service when the bed makes strange noises or movements.

Activate the brakes when the bed does not have to be moved. Please ascertain yourself of this by trying to move the hospital bed afterwards. By doing so, you minimize the risk of accidents when the patient tries to leave the bed. In order to increase the patient's safety, it is advisable to put the bed in its lowest position, especially when the patient is sleeping. Make also sure that the bed has been put in its lowest position before you leave the patient alone without supervision. Furthermore, the bed has to be put on a flat, horizontal surface.

Never remove the bed when the castor brakes are activated. You should also make sure that certain bed accessories (lifting pole, IV rod...) do not hinder a safe and fluent passage through doors and the like. Please be careful when moving the bed and avoid collisions, especially with other persons.



Never take place on a mattress platform without a mattress. To guarantee the safety, the bed has to be equipped with a mattress that complies with the following specifications:

Mattress dimensions (standard width): 85 x 195 cm

Mattress dimensions (width 90 cm): 89 x 195 cm

Minimum mattress thickness: 12 cm

Maximum mattress thickness, depending on the type of sideguards:

Atmosphere: 14 cm

Atmosphere heightened: 22 cm

Pollux: 14 cm

Trix: 16 cm

Minimum stiffness of the foam: 2,8 kPa in accordance with ISO 3386 (CLD/40%)

Fire retardant material

In case visco-elastic foam is used, a supportive layer of minimum 7 cm with a minimum stiffness of 3,6 kPa in accordance with ISO 3386 (CLD/40%) has to be used.

**In case the customer has ordered a special mattress platform, the mattress dimensions have to be adjusted accordingly.**

The Trendelenburg-position (optional) may only be activated by persons that have received a medical training. Please switch off all electric functions that may not be used by the patient (optional) or place the hand control out of reach of the patient.

When you use additional or peripheral equipment, you have to make sure that everything has been installed correctly and that everything functions properly. Please avoid using loose cables or wires and do not use multi-sockets. Contact your supplier or Haelvoet NV if you have any questions about peripheral equipment.

Devices that create strong electromagnetic fields and that may possibly influence the control of the bed are not permitted in the direct vicinity of the bed. Take also into account that the bed creates electromagnetic fields and may possibly influence the (measure) equipment used near the bed. However the bed is approved according to EN 60601-1-2, residual risks are possible.

The bed may not be used when there is a risk of explosion. It may also not be used near inflammable, volatile anaesthetic gases.

When you think that there is some damage or that the bed does not function properly, you have to disconnect the bed immediately. You also have to indicate clearly on the bed that it is OUT OF USE. Furthermore, contact the person who is in charge of the beds as soon as possible.

The bed may only be used when the following ambient conditions are present:

- Temperature: between 5°C and 40°C.
- Humidity of 20% to 90% at 30°C without condensation.
- Atmospheric pressure between 700 and 1060 hPa.

## 1.2 Moving sections



Make sure that you can't get stuck between or in the moving sections, even if these sections are not activated.

All sections should be able to move freely (do not install the bed near a windowsill or other obstacles). Make sure that the mains cables of peripheral equipment (patient lift, compressors, reading lamp,...) can never get stuck or damaged during a bed manipulation.

## 1.3 Sideguards



If the bed is moved with the patient still in it, the sideguards must always be put in their highest position. The same instruction applies when the patient is sleeping, or for all other circumstances, during which the nursing staff deems this necessary. Always check if the sideguards are locked properly.

Always put the different mattress platform sections and mattress platform inclination in the lowest horizontal position. Of course, this can only be done when the medical condition of the patient is not jeopardized. The aim of this action is to prevent that the patient gets stuck or can fall out of the bed. After all, this bed position guarantees the best patient protection.

It should, however, be stressed that the sideguards do not constitute an obstacle to stop people that wish to leave the bed wilfully. If the medical staff thinks this will happen, they should take the necessary precautions.

Never remove the bed by pulling at the sideguards. Only use undamaged, and technically perfect sideguards, of which the distances between the siderails comply with the statutory standards. Only use original Haelvoet sideguards, since these have been tested in accordance with the official standards. Regularly check if the sideguards still function properly.

Only use fitting, fire-retardant mattresses that have the correct dimensions and a sufficient hardness. Never use mattresses that are too thick. In order to protect the patient sufficiently, there always has to be a distance of 22 cm between the non-compressed mattress and the upper side of the sideguards.

Mattresses that are too thick cause an efficiency loss of the sideguards. If the required distance is not obtained, you have to opt for another mattress or extra aids, so that this safe height is always guaranteed.

Always check if the sideguards and the distances between the siderails guarantee enough protection for the patient. Do not forget to keep the patient's body figure in mind. It may be necessary to use additional protection equipment – such as a protective cover – for thinner and more fragile patients. Such accessories can be the only alternative to reduce the patient's risk from falling through the sideguards or getting stuck. Always pay attention to the physical and mental state of the patient and always take the necessary precautions.

**If you don't keep the above-mentioned guidelines in mind, a patient can run the risk of getting stuck between the siderails. If the distances between the siderails are too big, the patient can also fall out of the bed. These distances can be caused by damage, incorrect usage or faulty sideguards. It is also possible that this has happened because the sideguards have been locked incorrectly.**



## 1.4 Bed/foot extension



The bed is standard equipped with a bed extension and can be optionally equipped with a foot extension. If the bed extension is used, the gap created between the footrest and the foot panel has to be filled. This can be done by means of the optional telescopic foot extension or removable foot extension, so that there is no gap larger than Ø 11 cm between the mattress platform, panel and the sideguards.

## 1.5 Preventive maintenance

All bed functions should be checked at least annually. For this purpose we refer to chapter X of this manual.

The bed may only be repaired by a qualified technician in case of a malfunction or defect. Disconnect the bed immediately and clearly indicate on the bed that it is "OUT OF USE". Contact the person who is in charge of the bed as soon as possible. Repairs by unqualified persons may cause severe damage or injuries.

## 1.6 Mains cable

When installing or removing the bed, please ascertain yourself of the fact that the bed does not stand on the connecting cable or that the cable is not jammed between the moving sections. Never ride with the bed over the connecting cable or pull at it.

Please check the mains cable at regular times. Pay attention to any damage (e.g. compressed, a kink, open wires, etc.). Make sure that the cable is not jammed, and never ride with the bed over the mains cable. Never remove the bed without first disconnecting the mains cable. Also ascertain yourself of the fact that the strain relief sufficiently clamps the mains cable.

Pull the plug out of the socket when you want to clean the bed or perform an intervention on it.

## 1.7 Battery (optional)

Never try to bore the battery. Never throw it in a fire. Please return the replaced batteries to the manufacturer or dealer for recycling.

If a bed or control box with internal batteries has not been used and/or connected to the net for a long period, it is recommended to remove the batteries. By doing so, you avoid problems with leaking batteries.

## 1.8 Spare parts and options

Only use spare parts or options that have been approved by Haelvoet NV.

Haelvoet NV cannot be held liable for any damage or injuries resulting from modifications to the bed, and/or the use of non-original spare parts or options without the knowledge and written consent of the manufacturer.

## 1.9 Alarm signals

If the Olympia Care bed is equipped with a battery, then it also has a battery alarm signal.

If the capacity of the battery is going below a safe level to guarantee the electric functions of the bed, a warning signal will sound at the moment when one of these functions is activated. Connect the bed to the net as soon as this warning signal sounds.

# 1.10 Applied parts

1	Bedpanels
2	Sideguards
3	Mattress platform parts

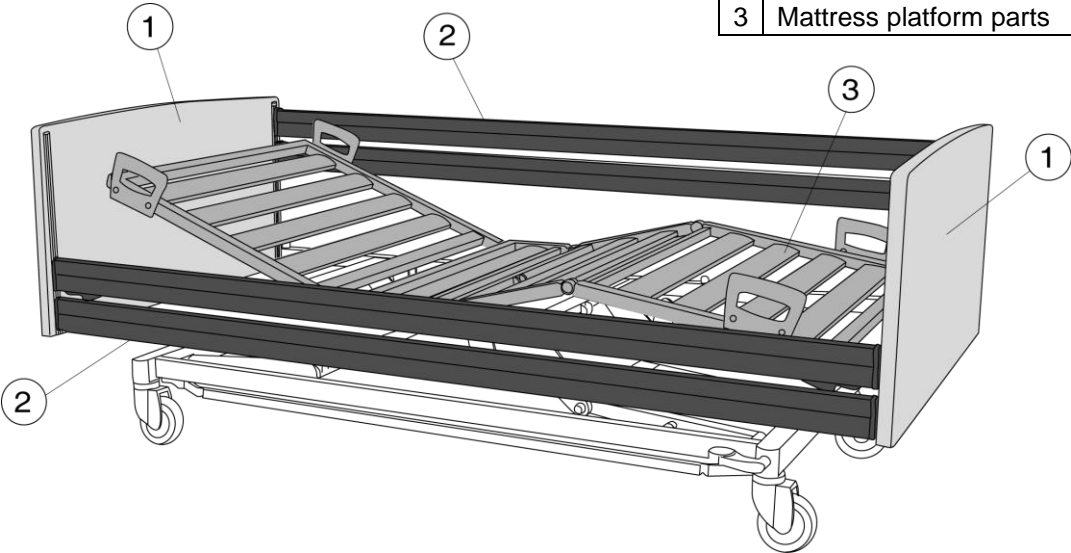

Figure 1.3: Applied parts



# II. OPERATING INSTRUCTIONS

## 2.1 Electric functions



Please always explain the electric functions to the patient, and inform him about the possible risks while using the bed. Users may only operate the bed when they have sufficient knowledge or experience with the bed. Patients with impaired physical or mental capabilities may only manipulate the bed when there is sufficient supervision.

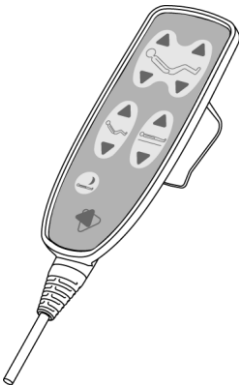

Figure 2.1: Hand switch

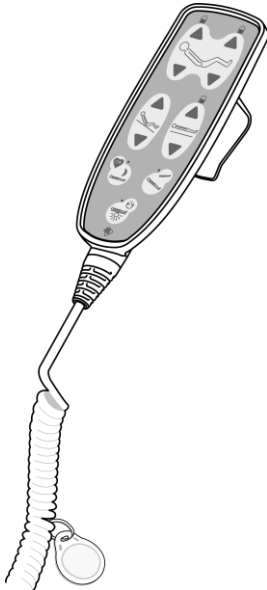

Figure 2.3: Hand switch with magnet key (optional)

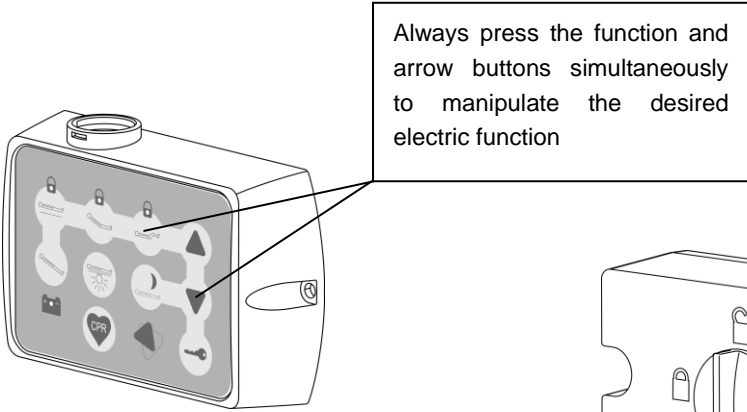

Figure 2.2: Mini nurse box ACC (optional)

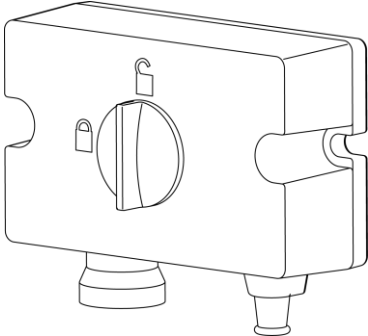
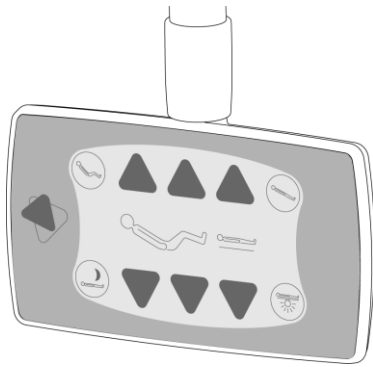

Figure 2.4: Lock box ACL (optional)



**Figure 2.5: Satellite control FPP (optional)**



**Figure 2.6: High/Low foot pedal (optional)**

Remark: The lock box and mini nurse box is situated on the left side of the bed near the fixed mattress platform section.

All electric control buttons are *Momentary Touch buttons*. The number of bed functions depends on the ordered bed configuration.

When 2 function buttons are touched simultaneously, the control will consider this an error. All electric bed manipulations will be stopped immediately.

The hand switch can optionally be put in a flexible holder, which results in an optimal accessibility of the hand switch for the patient (see 3.5)



**Make sure that the patient and especially children cannot reach the hand switch, or block the electric bed functions (option) in order to guarantee the patient's safety. This applies for the following cases:**

- **When children are near the bed without supervision**
- **If a bed manipulation can be dangerous for the patient**
- **If the sideguards are put in their highest position. In this case, the patient can run the risk of getting stuck in the sideguards during a bed manipulation**
- **If the patient is not capable of operating the bed safely, or when he can put himself in danger by operating the bed**
- **If additional equipment or accessories can be dangerous or harm the patient.**

Only qualified and trained personnel are allowed to operate the bed in the above-mentioned cases.

Please keep the 10% rule in mind. Never operate the bed continuously longer than 2 minutes. When you have used the bed continuously for 2 minutes, you have to make sure that the bed is not activated for at least 18 minutes.

Despite the fact that the electric bed equipment complies with all regulatory obligations, there is still a chance that there is a interference on another device during a bed manipulation. If this is the case, you have to put the other equipment further away from the bed and connect it to another net.

### 2.1.1 Electric function possibilities



**Make sure that no part of the body is situated between the moving parts.**

#### a. Backrest adjustment: electric



This function can be activated by means of the hand switch, satellite control (optional) or mini nurse box (optional).

Maximum angle of inclination = 70°. The angle between the backrest and knee rest is always at least 90°.

#### b. Knee rest adjustment: electric (option)



This function can be activated by means of the hand switch, satellite control (optional) or mini nurse box (optional).

Maximum angle of inclination = 34°. The angle between the backrest and knee rest is always at least 90°.

#### c. High-low adjustment: electric



This function can be activated by means of the hand switch, satellite control (optional) or mini nurse box (optional).

The mattress platform can be adjusted in height, even when it is put in a Trendelenburg or Reverse-Trendelenburg position. When the mattress platform is activated upwards or downwards, it will take a horizontal position as soon as the front or back of the mattress platform reaches its highest or lowest position.

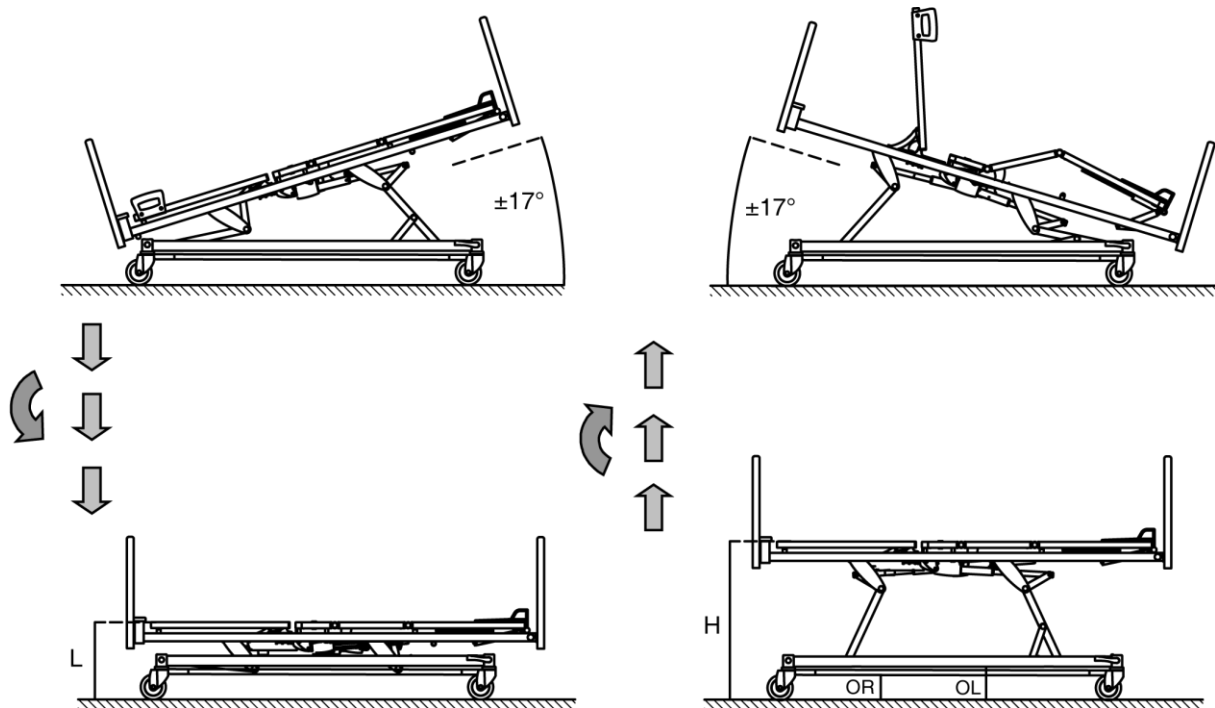

Castor version:	L in mm *	H in mm *	OL in mm*	OR in mm*
Levina Ø125mm (standard )	360 mm	785 mm	167 mm	134 mm
Integral S Ø150mm	380 mm	805 mm	187 mm	154 mm
Hidden twin castors Ø50mm	352 mm	777 mm	159 mm	126 mm

\* L : With Trendelenburg +25mm

\* OL : left side of the bed

\* OR : right side of the bed, reduced height for the central brake system

Figure 2.7: Depiction of the electric HL-adjustment

Keep in mind that the mattress platform can be put in a horizontal position by means of the hand switch, provided that the high-low function is not blocked by the nurse box or mini nurse box.



***Please make sure that nobody is under the mattress platform before you activate this manipulation! Make sure that there are no objects on or around the carriage that can block a height variation.***

***Put the bed in its highest/lowest position on a regular basis, so that it can reset itself.***

d. Trendelenburg/Reverse-Trendelenburg: electric



The Reverse-Trendelenburg position can be activated by means of the hand switch, satellite control (optional) or the mini nurse box (optional), whereas the Trendelenburg position can only be activated by means of the optional mini nurse box. The Trendelenburg position may only be activated by persons who have had a medical training. These persons should take the medical condition of the patient into consideration.



**Make sure that nobody is under the bed before activating this function!**

e. Relax/seat position: electric (only for a mattress platform with 4 sections)



This function is only available on the hand switch and satellite control (optional). When activating this function, the backrest and knee rest are inclined simultaneously.

f. Sleeping position: electric

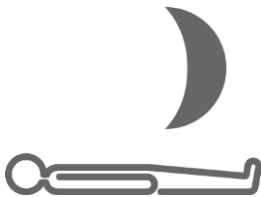

This function can be activated by means of the hand switch, satellite control (optional) and mini nurse box (optional). All mattress platform sections are put horizontally, whereas the bed is placed in its lowest position, by pressing one single button.



**Never overload the bed, not even for a short period. In case you have no other option owing to circumstances, please put all mattress platform sections in a horizontal position. Also put the bed in its lowest position.**

## 2.1.2 Extra nursing functionalities on the hand switch HD with magnet key (optional)

With a magnet key  the extra nursing functionalities of the hand switch are activated during 5 seconds.

If during these 5 seconds, no action has been taken, the hand switch turns back to the standard functionalities.

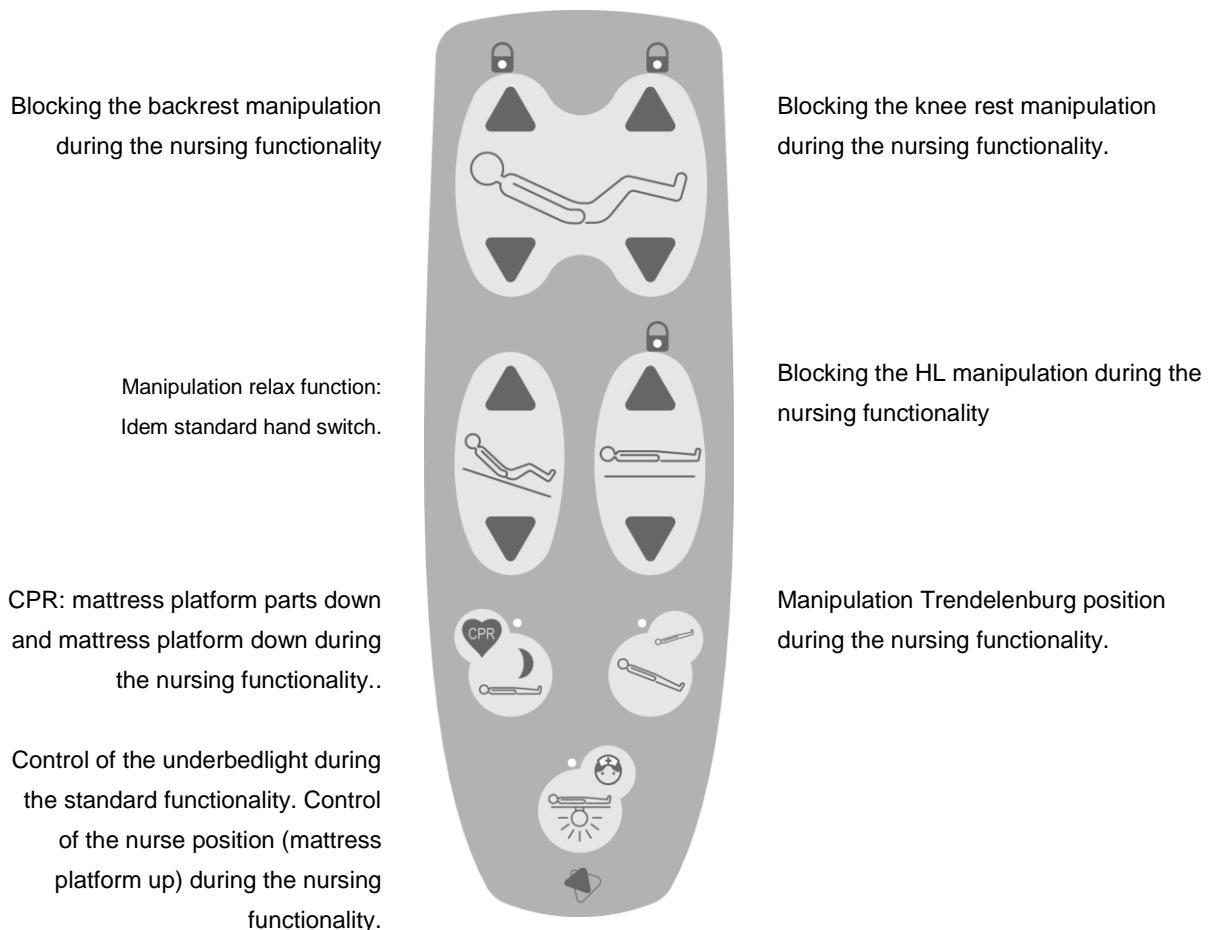

**Figure 2.8: Extra functionalities on hand switch HD with magnet key**

Always put the hand switch outside the reach of the patient, or block the electric functions, if these functions constitute a danger for the patient. This rule also applies for transport, maintenance,...

### 2.1.3 Blocking of the electric functions (options)

The following functions can be switched off by means of the mini nurse box (option) or the lock box (option):

1. backrest adjustment
2. knee rest adjustment
3. high-low adjustment and Trendelenburg – Reverse-Trendelenburg (simultaneous)

The block button on the lock box (option) makes it possible to switch off all functions.

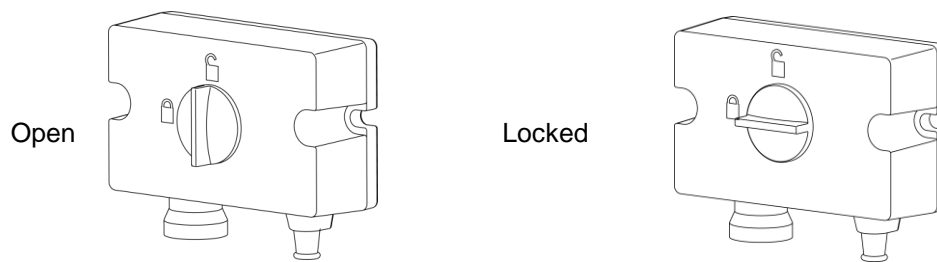

**Figure 2.9: Blocking of the electric functions on the lock box**

To do so, you have to press the function button and block button simultaneously. A LED indication shows which function is blocked.

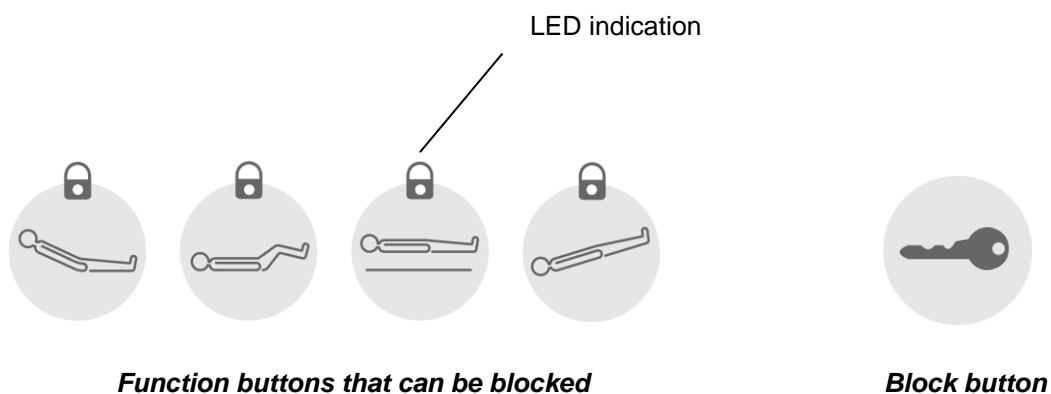

**Function buttons that can be blocked**

**Block button**

**Figure 2.10: Blocking of the electric functions**

These functions cannot be activated by the hand switch, nor by the mini nurse box (optional) after they have been blocked. Always check this block function in case the bed does not want to perform a certain function.

Always put the hand switch outside the reach of the patient, or block the electric functions, if these functions constitute a danger for the patient. This rule also applies for transport, maintenance and the like.

#### **2.1.4 Battery (optional)**

Charge the battery completely (at least 12 hours) before you start using the bed. Always connect the bed to the net, because frequent, high and long discharges can influence the battery's life span negatively.

The battery's life span by correct use is minimum 3 years and depends on how much you use it.

Only use the battery when there is an electricity breakdown or when you transport the patient. An alarm signal warns you when the battery capacity is not sufficient enough anymore during an electric manipulation. If this is the case, you have to connect the bed to the net immediately.

#### **2.1.5 Illuminated hand switch (option)**

The push buttons on the hand switch are illuminated in light green when activated (only available with a 4-section mattress platform). This makes it easier for the patient to use the hand switch in a dim room.

#### **2.1.6 Nightlight under the bed (option)**

A nightlight is installed under the mattress platform. Thanks to this, the patient can find his way in a dim room, without having to contact the nursing staff or the patients.

The nightlight is activated by pressing the function button on the satellite control or mini nurse box.



**Figure 2.11: Nightlight under the bed**

#### **2.1.7 Reset Procedure**

A fault of the control of the bed is visible in following cases:

- The green LEDs on the hand switch flash
- A signal sounds when pressing a function

The control of the bed needs to be reset as described in Fig 2.12



## Reset Procedure

Push both functions on the 2nd row at the same time. An acoustic signal confirms the start of the reset procedure. Keep the buttons pressed till the signal has stopped.

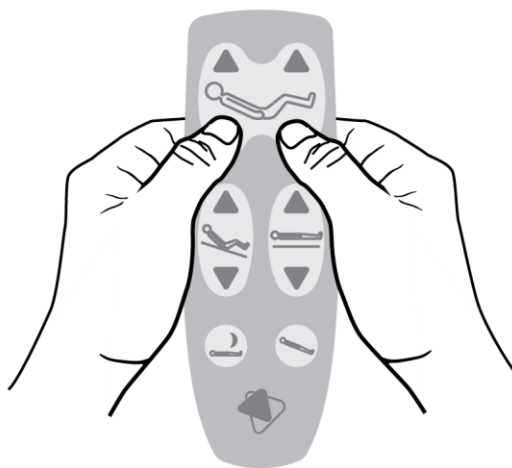

Bring the bed to its lowest position to initialize the software.

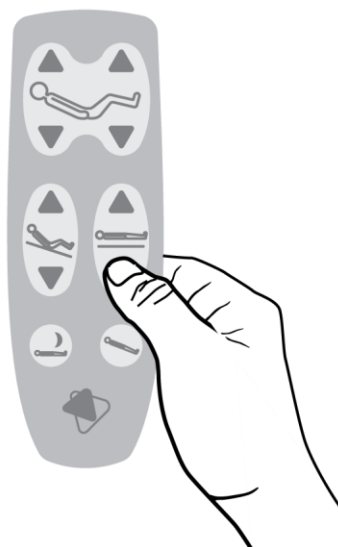

**Figure 2.12: Reset procedure**

## 2.2 Mechanical functions

### 2.2.1 CPR: manual (optional)

A red CPR lever (optional) is installed on both sides of the fixed mattress platform section.

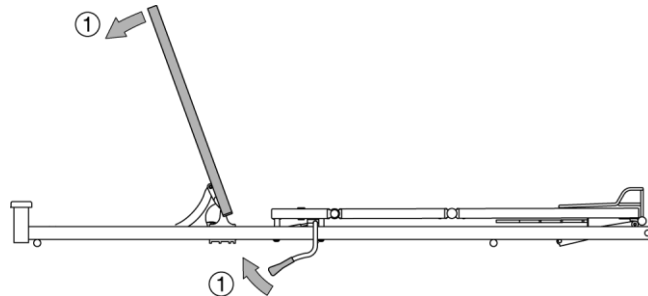

Figure 2.13: CPR-lever

The backrest can be manually brought downwards by activating the CPR lever towards the headrest.



**In order to maximize the product life of the actuators and the quick release, it is of the utmost importance that this lever is only used in EMERGENCY SITUATIONS.**

**Make sure that there are no objects that hinder the free movement of the backrest. Please take all necessary measures to prevent that the patient or nurse can get stuck. For this reason, you first always have to put the sideguards in their lowest position.**

### 2.2.2 Leg- and footrest adjustment: manual

The leg/footrest is equipped with two telescopic adjusters. Six different positions can be obtained. The leg/footrest can always be put in its lowest position by lifting it a little. Hold the leg/footrest tight, so that it cannot fall suddenly.

- Legrest: up to approximately 14°

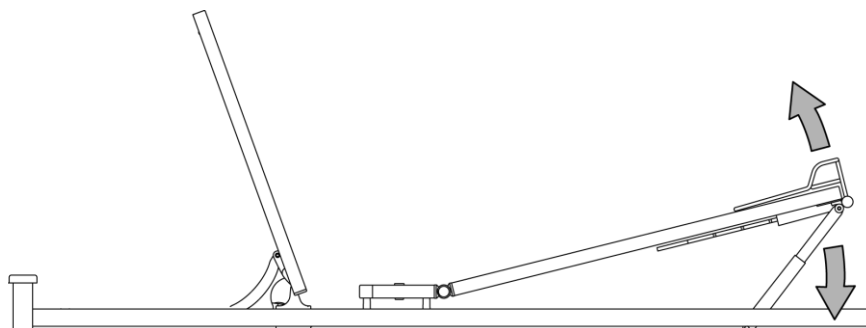
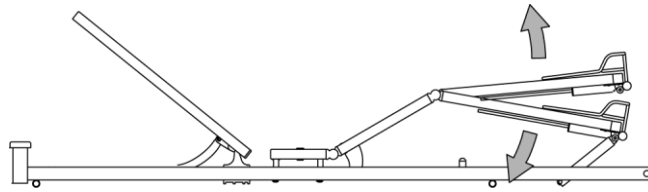

Figure 2.14: Legrest

- Footrest: at a knee rest adjustment of 34°

From 2° till about -17°



**Figure 2.15: Footrest**

### 2.2.3 Mattress platform

The mattress platform of the Olympia Care consists of 3 or 4 sections. These sections are made of a steel frame with rounded laths of bent steel plate. The mattress platform can be optionally equipped with removable synthetic vacuum sections. These sections can be easily cleaned, thanks to their excellent design and fluent detachability.

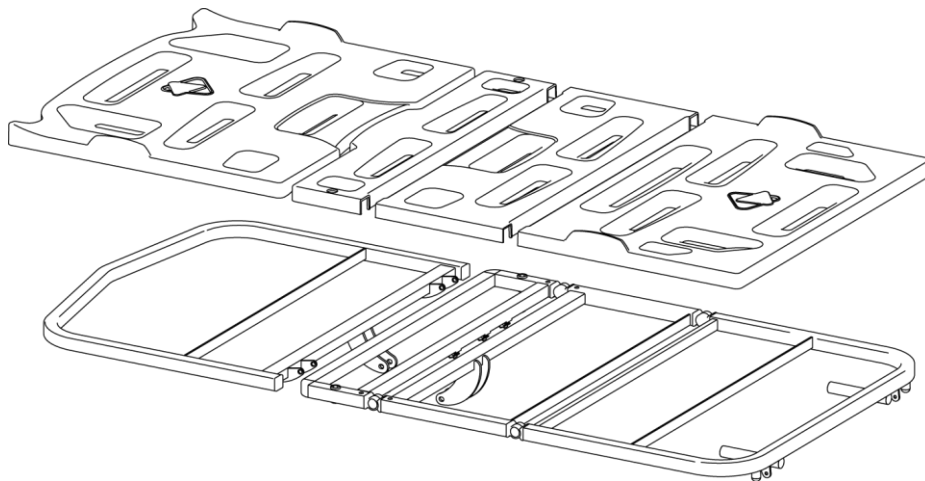

**Figure 2.16: Removable mattress platform sections**

### 2.2.4 Separate brake

The four castors all have separate brakes. By stepping on the brake, as shown in figure 2.16, the castor brake is activated

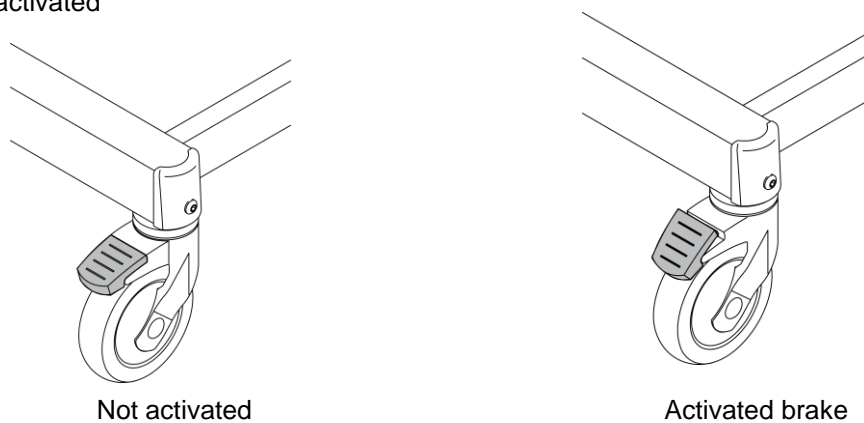

**Figure 2.17: Separate brakes**

### 2.2.5 Central brake

The carriage is equipped with a design brake pedal on both sides of the foot end. The bed is standard equipped with a single brake pedal. The bed can be optionally equipped with a double brake pedal. Both types activate all 4 castors simultaneously, and can be set in three positions.

- 4 activated castor brakes

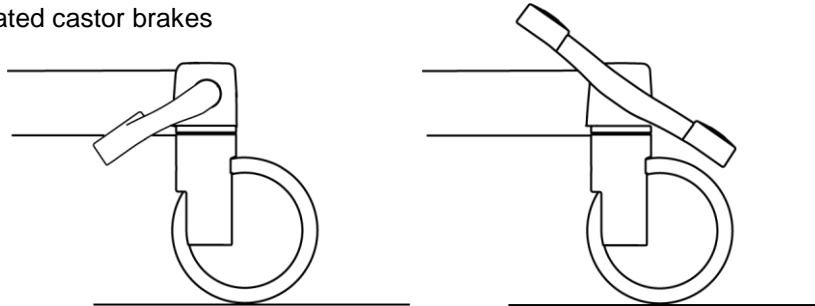

Figure 2.18: 4 activated castor brakes



**Disconnect the bed from the net, and put the mains cable on the suspension hooks. Always put the sideguards in their highest position, and release the brake before moving the bed.**

- 4 non-activated castor brakes: This position makes it possible to move the bed in all possible directions.

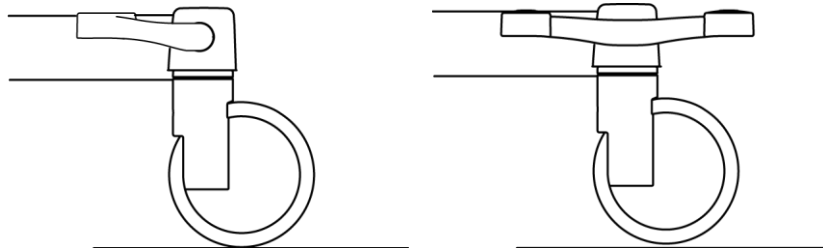

Figure 2.19: 4 castor brakes, non-activated

- Directional castor: This position guarantees that one castor cannot swivel, which makes it easier to move the bed in a straight line.
- Always make sure that the directional castor is set in the same position as the other castors. If this is not the case, a stable and straight-lined bed course cannot be guaranteed.

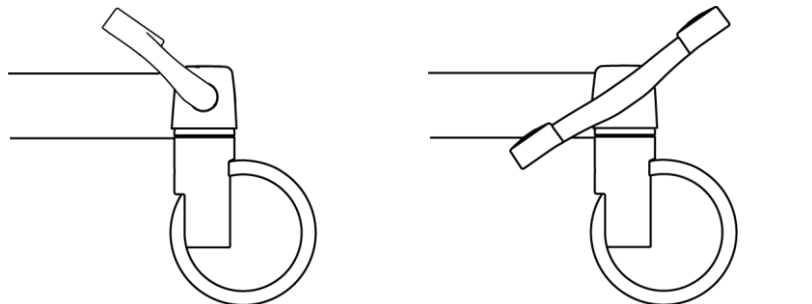

Figure 2.20: One directional castor



**Never pull or push at the side of the bed when the directional castor has been activated.**

The castors leave no marks on tiles, carpets, linoleum or laminate floors. Please check if the castors leave marks on parquet floor because of the use of parquet cleaning products.

The castors have been developed to be used on smooth and cleaned floors. The castors can be damaged when you use them on rough, uneven and dirty floors

### 2.2.6 Moving the bed

The following steps must be followed to remove the bed in a safe and durable way:

- Put the sideguards in their highest position.
- Put the bed in a transport height that suits you.
- Disconnect the plug from the net and hang the mains cable to the suspension hooks at the head end.



**Never pull the mains cable, and never remove the bed without disconnecting it from the net.**



**When the mains cable has not been stored properly during transport, the risk of mains cable damage or electrocution increases substantially. Please make sure that the mains cable is not torn off, squeezed or crushed. Do not ride the bed over the mains cable.**

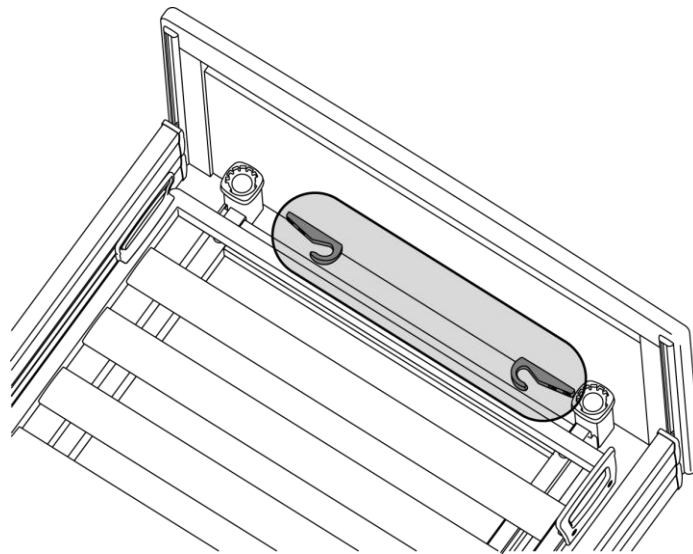

**Figure 2.21: Suspension hooks for the mains cable**

- Take the foot panel with both hands.
- Release the central brake and activate, if necessary, the directional castor.
- Make sure that the bed and all its accessories (lifting pole, IV rod,...) can pass through the doors without any problems.
- Please be careful, when moving the bed, not to hit other persons.
- Activate the central brake as soon as the bed has been brought to a standstill.

### 2.2.7 Telescopic bed and footrest extension (option)

The telescopic bed and footrest extension (optional and not possible with Pollux sideguards) is part of a possible bed configuration. This mechanism is installed at the foot end and has to be activated as follows:

- Put the sideguards in their highest position to have a better access to the block buttons and the footrest extension.
- Pull the block buttons at the exterior of the right and left side beams and rotate them a little

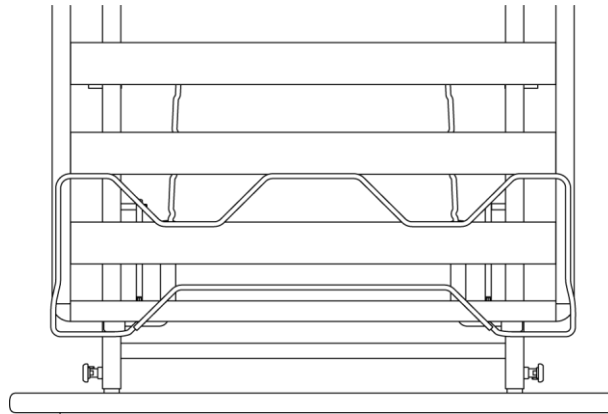

**Figure 2.22: Access to the bed extension**

- Pull the cross beam until the desired extension has been obtained. The bed can be extended to maximum 20 cm. The extension happens in steps of 5 cm.

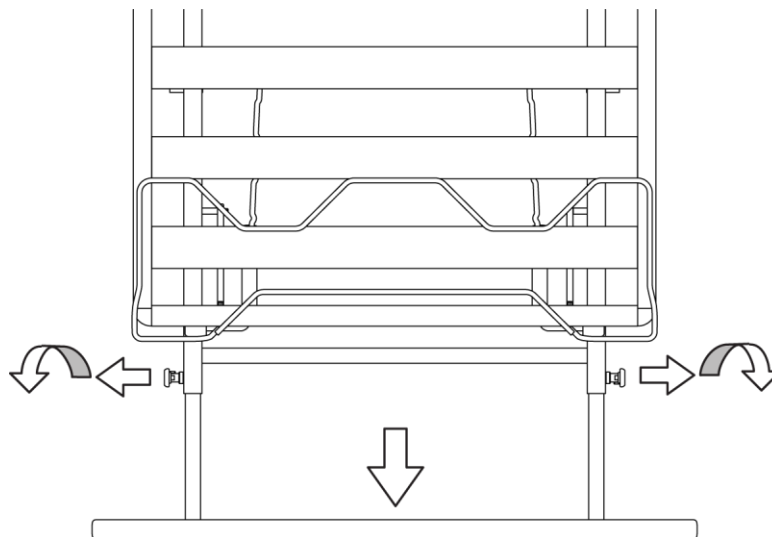

**Figure 2.23: How to extend the bed**

- Put the block buttons back in their original positions and make sure that they lock the mechanism. Check this by trying to extend or shorten the bed.
- Extend the telescopic foot extension in the same distance.(optional) or install the removable mattress platform extension.

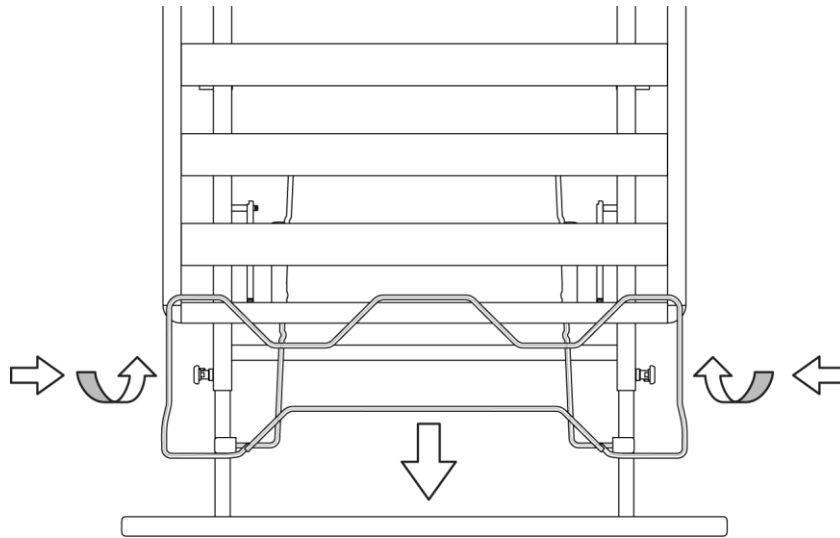

**Figure 2.24: Extension of the foot end (option)**

- Make sure that the mattress reaches the foot panel, and put the mattress extender at the head end.



**Always fill the created gap with the telescopic foot extension or removable mattress platform extension and with a suitable mattress, so that the patient cannot get stuck.**

### III. POSSIBLE OPTIONS

The Olympia Care bed can be equipped with:

Options	Accessories	
	IDnr	Description
Sideguards Atmosphere	00441	Flexible hand switch holder
Sideguards Pollux	01840	Lifting pole
Sideguards Pollux +20cm	01856	IV rod
Sideguards Trix	01863	Document holder A4 (horizontal)
Sideguards Trix with 4 <sup>th</sup> rail	01864	Document holder A4 (vertical)
Telescopic bed extension	03576	Document holder A3 (horizontal)
Telescopic footrest extension	02755	Dinner tray to install onto the sideguards
Accessory hooks	03296	Urine bottle holder (vertical) (only if the bed is equipped with accessory hooks)
Wooden side laths for mattress platform frame		
Quick release for backrest	10625	Urine bottle holder (horizontal) (only if the bed is equipped with accessory hooks)
Lock box ACL		
Mini nurse box ACC	05878	Bowl holder (only if the bed has been equipped with accessory hooks)
Satellite control FPP		
Illuminated hand switch	06366	Oxygen bottle holder
Nightlight under the bed	07180	Raising aid
EPR mains cable	08004	IV rod to attach to the lifting pole
4 bumpers (not with Midea panels)	09242	Bed pan hook
Wall protector	09629	Accessory brace (only if the bed is equipped with accessory hooks)
Inclination indicator		
Wall protectors on the carriage	09945	Removable mattress platform extension
Battery with alarm signal		
High/Low foot pedal		



## 3.1 Sideguards



Please follow all safety instructions of paragraph 1.3 at all times!

### 3.1.1 Type Atmosphere

Weight: Set of sideguards: 13.8 kg

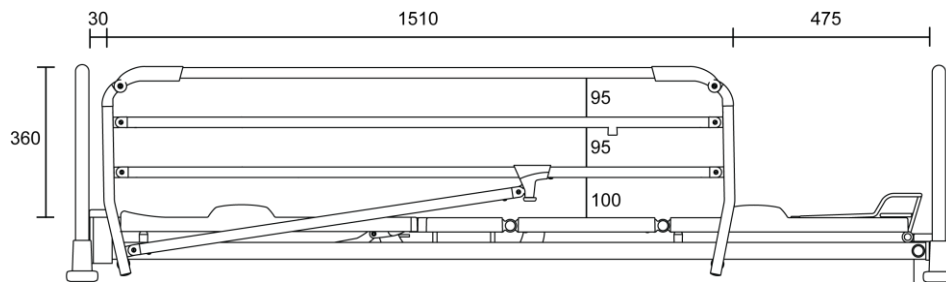
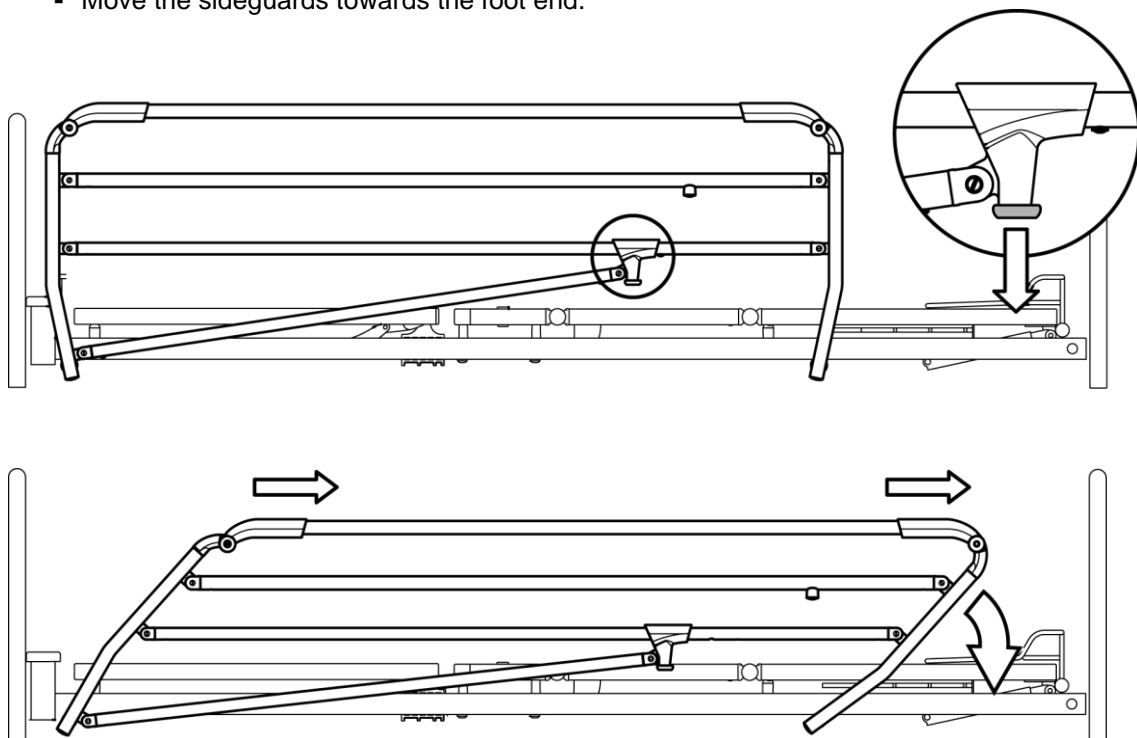
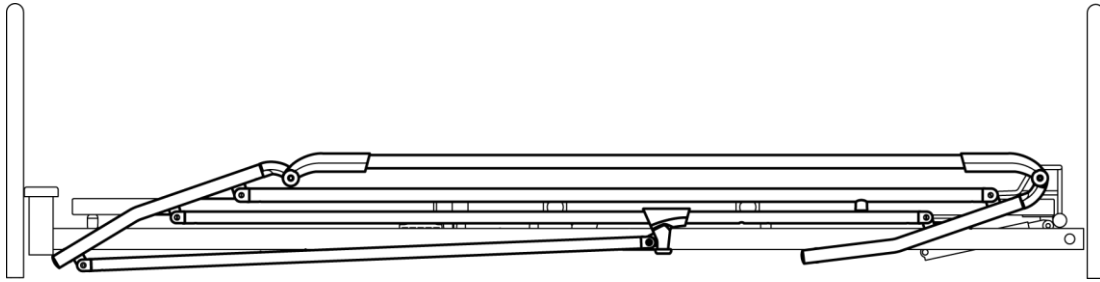

Figure 3.1: Sideguards Atmosphere: dimensions

These sideguards are attached to the bed frame and form one unity. The undermentioned method has to be followed to lower a sideguard:

- Take the sideguard handle at the head or foot end with one hand
- Pull the pull knob in the middle of the bottom tube with the other hand.
- Move the sideguards towards the foot end.





**Figure 3.2: Manipulation of the sideguards type Atmosphere**

### 3.1.2 Type Atmosphere heightened (option)

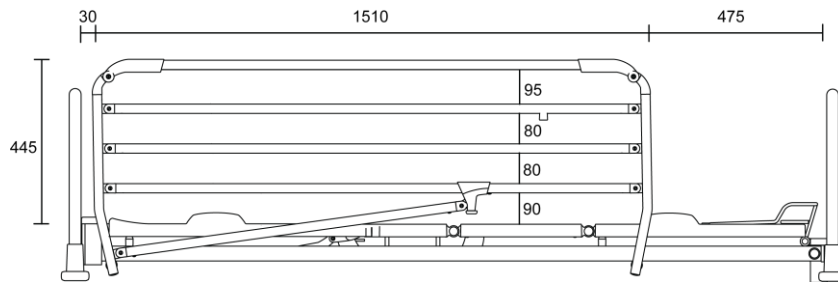
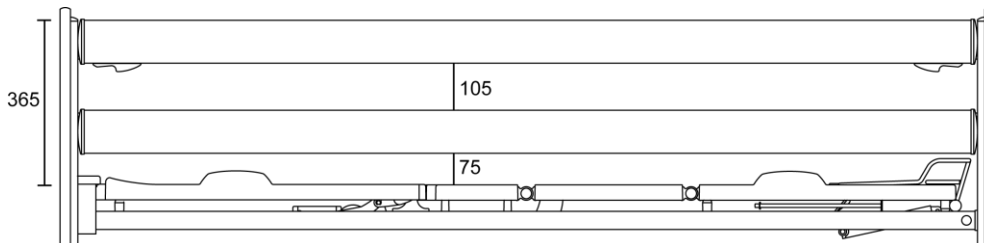

**Figure 3.3: Sideguards Atmosphere heightened: dimensions**

The heightened sideguards Atmosphere are composed of 5 tubes and have the same function as the standard Atmosphere.

### 3.1.3 Type Pollux

Weight set of sideguards: 15 kg.



**Figure 3.4: Sideguards Pollux: dimensions**

The design of the Pollux sideguards is the answer to the demand of the health care sector for safe and aesthetic sideguards. These sideguards are attached to an aluminium guiding rail that has been put on the wooden front panels of the bed. The sideguards consist of two rails. The strong wooden laths fence the bed sides over the entire length. A guaranteed distance between the two laths makes sure that the Pollux sideguards comply with the strictest regulations.

A safety system has been developed to prevent the sideguards from being lowered unintentionally.

The following steps must be followed to lower the sideguards:

- Take the lock system under the upper lath with one hand.
- Pull the lock system towards the middle of the bed while lifting the lath a little.
- Hold the lock system backwards and lower one side of the sideguards.

- Repeat these steps to lower the other side of the sideguards.

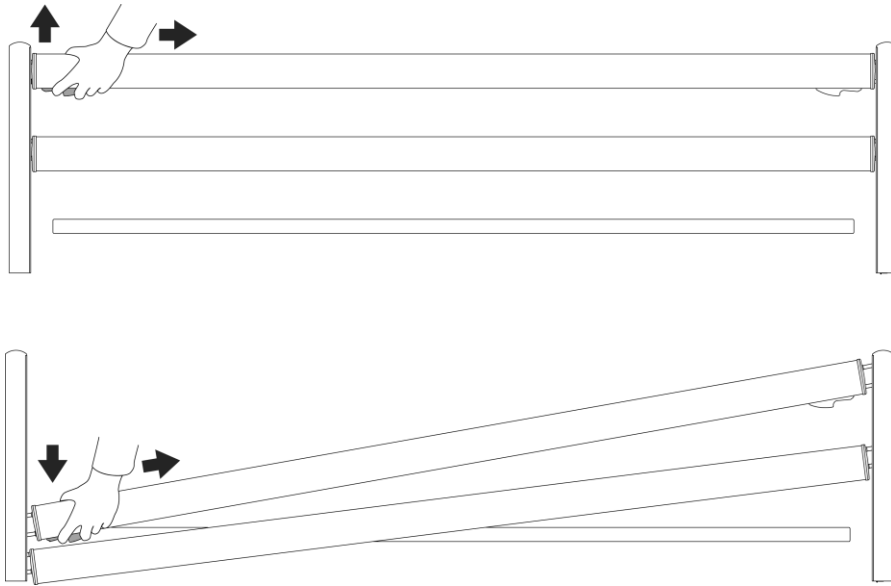
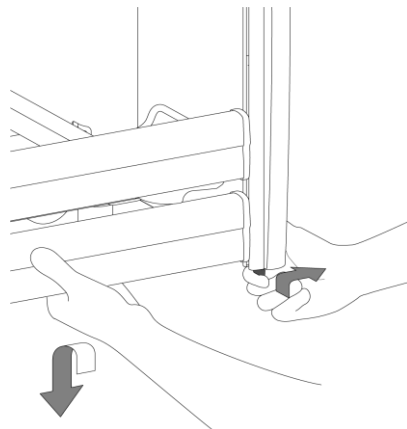

**Figure 3.5: Manipulation of the sideguards type Pollux**

### 3.1.4 Type Pollux extended

Longer Pollux sideguards are optionally available (maximum extension = standard + 20 cm). The following steps have to be followed to install these sideguards on the mattress platform:

- Remove the standard Pollux sideguards: put the sideguards in their highest position, remove the lock screw at the bottom of the guiding rails, and remove the sideguards by lowering them and taking them out of the guiding rails.
- If the bed is equipped with Midea panels, you have to release the locking clip below the siderail, by pushing it upwards and then backwards. While doing so, hold the siderails a bit upwards, so that they don't exert any pressure on the locking clip. Then lower the first siderail until it can be completely removed. Continue to hold the locking clip backwards. Repeat this on the other side of the rail.



**Figure 3.6: How to remove Pollux sideguards with a locking clip for Midea panel**

- Remove the foot panel bolts on both sides of the mattress frame.
- Extend the mattress frame in accordance with the length you chose for the Pollux sideguards. This can be done by simply pulling out the panel.
- Fasten the panel again by means of the bolts.
- Make sure that at least one side lath with a lock mechanism (upper lath) is installed on both sides. Also make sure that at least one side lath without a lock mechanism is installed on both sides.
- Take the side lath with the lock mechanism and insert the guiding pin with the synthetic bracket. The long groove of the synthetic bracket has to be aimed upwards. One alu guiding pin has to be installed at the top, whereas two alu pins have to be installed at the bottom.

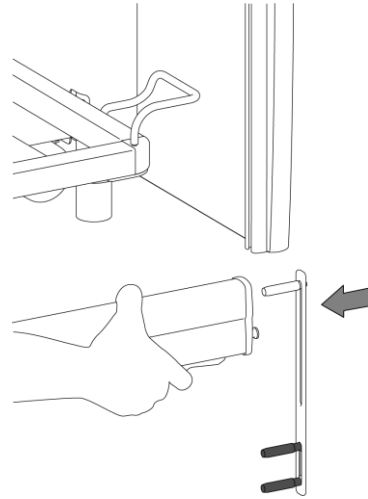

**Figure 3.7: How to install Pollux step 1**

- Insert the bracket and the guiding pins into the rail. While doing so, keep the lock mechanism backwards, so that the lath can be glided upwards without any problems. Repeat this at the other side of the side lath.

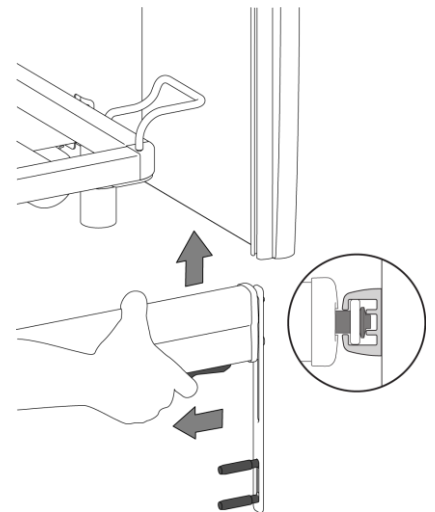

**Figure 3.8: How to install Pollux step 2**

- Put the side lath without the lock mechanism on the two alu guiding pins that have been installed in the synthetic bracket. Repeat this on the other side of the lath so that the lath is fastened.

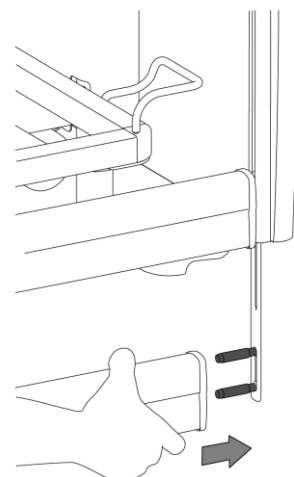

**Figure 3.9: How to install Pollux step 3**

- Bring the upper side lath upwards. While doing so, keep the lock mechanism of the side lath backwards, so that the lath can be glided upwards without any problems. As soon as the lower side lath is 5 cm above the underside of the panel, the lock screw has to be put back. Now you can release the lath. Repeat this action at the other side of the side lath.

If the bed is equipped with Midea panels, the siderails are locked automatically by means of the locking clip.

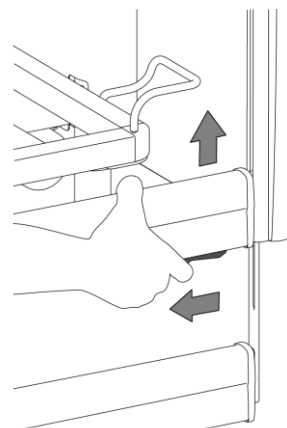

Figure 3.10: How to install Pollux step 4



**Make sure that the sideguards are locked properly. Check this by releasing the side laths. Exert from above a force of 100N on each side.**



**Extend the footrest extension (option) completely or fill up the gap between the footrest and the foot panel with a removable mattress platform extension.**

### 3.1.5 Type Trix

Weight: set of sideguards: 12 kg

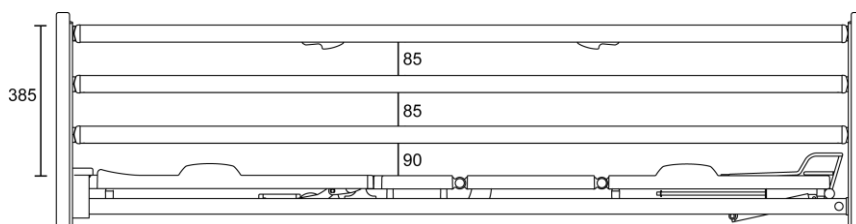

Figure 3.11: Sideguards Trix: dimensions

These sideguards are attached to an integrated rail of the aluminium stands of the wooden front panels. The sideguards consist of three laths. Thanks to the use of three laths combined with an ingenious lock mechanism, these sideguards comply with the strictest regulations.

The Trix sideguards cover the bed sides over the entire length. An integrated telescopic system makes sure that the Trix sideguards – even when the bed is extended (option) – cover the bed sides over the entire length. The sideguards can only be lowered by using your both hands; a safety system has been developed to prevent the sideguards from being lowered unintentionally. The sideguards are finished with a wood structure; they are very light and stiff.

The following steps must be followed to lower the sideguards:

- Take the handles under the upper lath with both hands.
- Pull these handles towards the middle of the bed while lifting the lath a little.
- Hold the handles towards the middle and lower the sideguards.

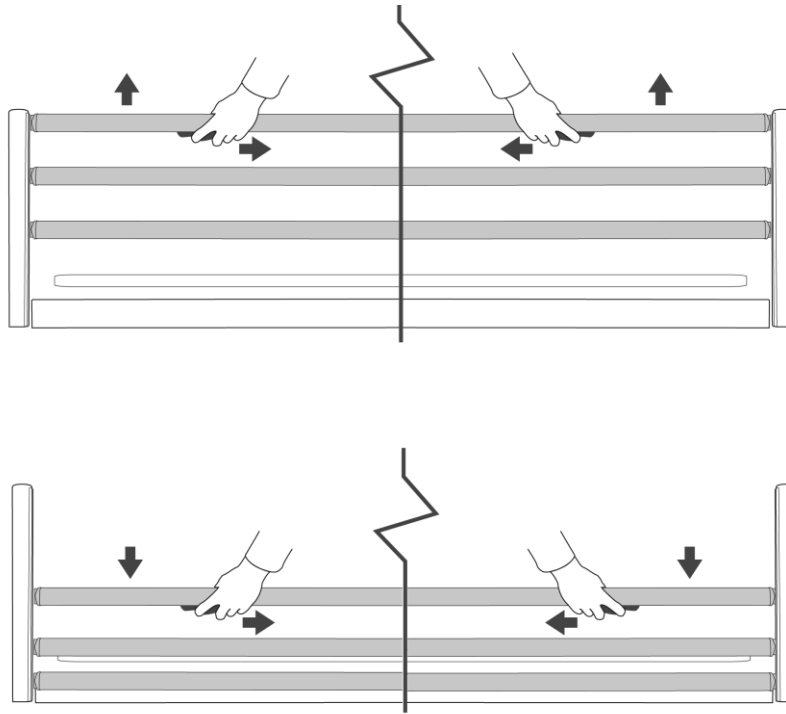

Figure 3.12: Manipulation of the Trix sideguards



**Never let the sideguards fall. Provide sufficient support while lowering them.**



**Pay enough attention to preventive maintenance, as described in the technical chapter of this manual.**



**Please always make sure that the sideguards are locked after having raised them. Please make sure that no part of the body or objects can get stuck between the sideguards. Always put the sideguards in their highest position when you intend to leave the patient alone.**



**The mattress platform should always be put in its lowest and most horizontal position, when the medical condition of the patient requires this (e.g. state of health at that moment or disorientation because of medicines), unless this has been imposed differently.**

## 3.2 Lifting pole

The lifting pole may only be installed in the right or left synthetic case **at the head end**. The lifting pole can be adjusted per 30°, but may **never** be swung outside the lying surface!



**Taking a safety margin into account, the maximum static load is 75 kg.**

**The lifting pole is not intended for rehabilitation exercises.**

It is recommended to check the suspension ribbon on a regular basis. It is also advised to replace the handle preventively every 4 to 5 years.

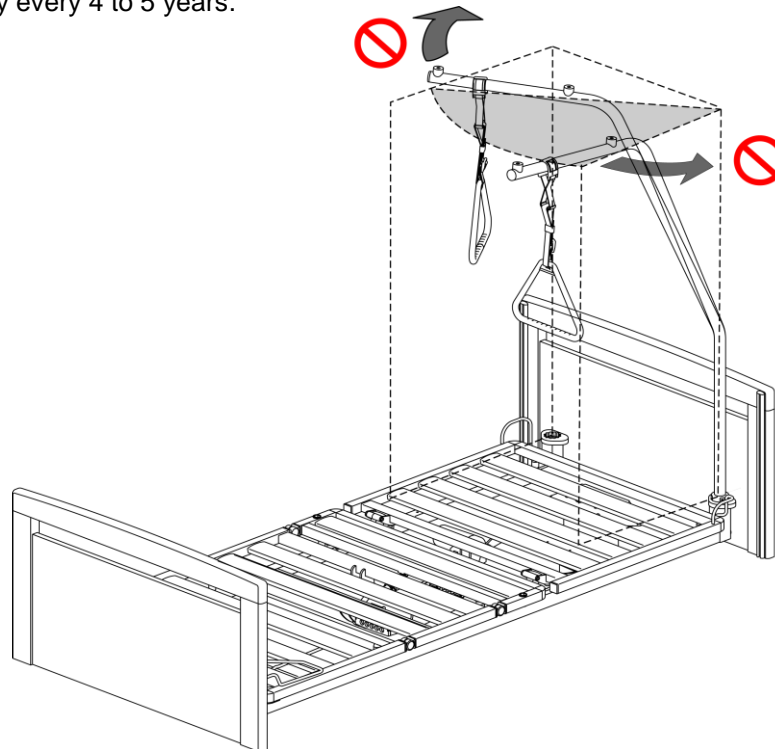

Figure 3.13: Exterior limits of the lifting pole

Weight: 4.5 kg



**If the bed has been equipped with a lifting pole or an IV rod, it is strongly recommended to pay attention to the zone surrounding the lifting pole and IV rod, especially when you manipulate the bed. By doing so, you prevent that the bed equipment or devices get damaged. Always make sure that the patient cannot get stuck.**

### 3.3 IV rod

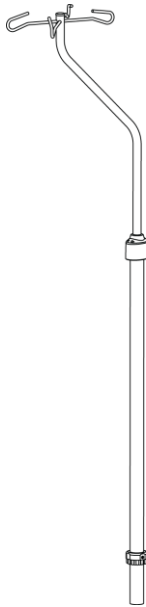

The IV rod can be placed in the synthetic cases of the 2 bed corners at the head end of the bed. The extending part should be held very firmly, before the turn knob is loosened to adjust the height of the IV rod. By doing so, you avoid that the IV rod glides unwantedly into the fixed part!

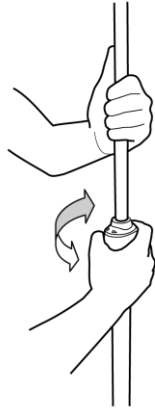

Figure 3.14: Adjustment of an IV rod

Weight of the IV rod : 3 kg  
Max. load on the hook: 2 kg  
Max. load on the IV rod: 8 kg

### 3.4 IV holder for the lifting pole

The lifting pole can optionally be equipped with an IV holder with 4 hooks. Always first install the IV holder on the lifting pole before hanging the handle and the ribbon on both devices.

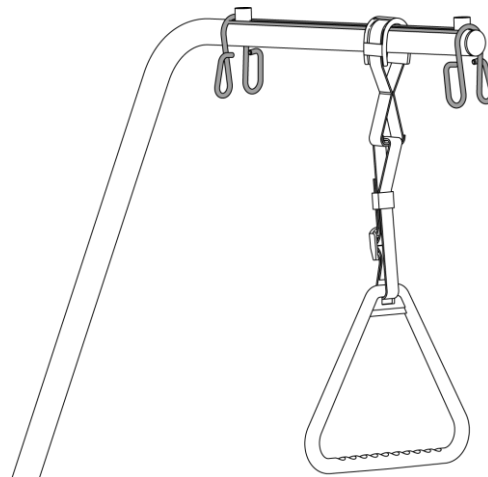

Figure 3.15: IV holder on the lifting pole

Weight of the IV holder: 0,37 kg.  
Max. load on the IV holder: 8 kg.  
Max. load on the hook: 2 kg.



### 3.5 Flexible hand switch holder

The flexible hand switch holder has to be installed in the provided left or right case near the fixed mattress platform section.

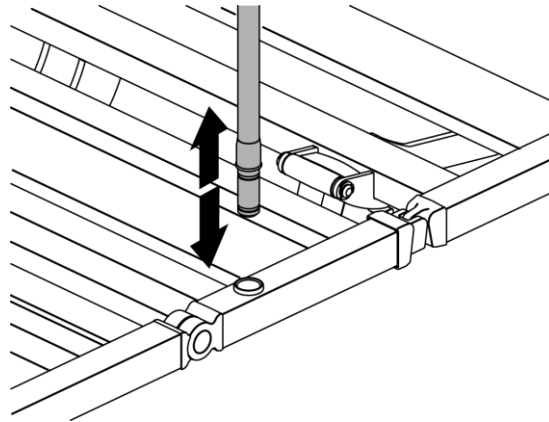

Figure 3.16: Installation of the flexible hand switch holder

Weight: 0,46 kg

### 3.6 Patient restraint straps

Thanks to its open structure, the metal mattress platform can be equipped with patient restraint straps over the entire length of the bed. For this purpose, the optional synthetic mattress platform is equipped with several reinforced cut-outs on the left and right side for patient restraint straps

### 3.7 Accessory hooks

The side beams can be optionally equipped with 3 synthetic accessory hooks on both sides of the bed. Several accessories can be optionally bought to attach to/in these synthetic hooks.

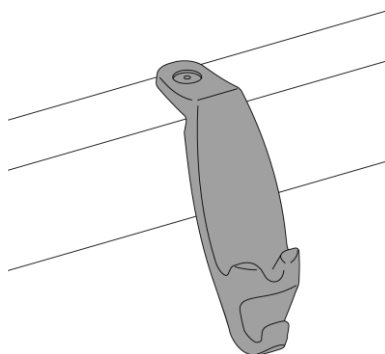

Figure 3.17: Accessory hooks

Max. load: 10kg per hook

## IV. CLEANING AND DISINFECTION OF THE BED

### 4.1 General information

You have to check the following items before you start cleaning or disinfecting the bed:

- Have the bed brakes been activated?
- Have the backrest and knee rest been put in a horizontal position? Has the bed been put in its highest position? By doing so, you make sure that the interior shaft of the actuator remains greased.
- Have all electric functions been switched off?
- Has the bed been disconnected from the net?
- Have all plugs been put correctly in the control box?
- Have you checked that all cables and electric parts are undamaged?
- Have you made sure that the personnel have appropriate outfits and material? (water-proof aprons and gloves, correct cleaning products,...)



**Ascertain yourself of the fact that the mains cable or electric components are not wet before connecting the bed to the net. If you think that water or disinfectants have seeped into an electric component, you have to disconnect the bed immediately and clearly indicate on the bed that it is “OUT OF USE”. Contact the person who is in charge of the beds as soon as possible.**



**All metal protective layers have a high abrasive resistance. Nonetheless, a metal component can have scratches that expose the underlying layer. Always repair this damage to avoid corrosion.**

**After having cleaned and disinfected the bed, it is important to disinfect your hands before going to another area or room.**

**Haelvoet NV cannot be held liable for any damage, injuries and impairments resulting from improper use of cleaning products or disinfectants.**

## 4.2 Degree of protection of the bed: IPX4



**Keep in mind that the bed is not wash tunnel-proof. Do not abundantly sprinkle the bed with water. It is absolutely forbidden to use a high-pressure cleaner.**

### 4.2.1 Cleaning

Remove the linen and wash it. Use a soft cloth - that is moistened with cold or tepid water - and a mild cleaning product or an all-purpose cleaner to clean the bed. Clean the bed afterwards with a moist cloth (without cleaning products) and wipe the bed carefully after the entire cleaning process. Make sure that the mattress platform is completely dry before the mattress is put back.

Avoid:

- Alcoholic cleaning products
- Corrosion-stimulating or aggressive cleaning products
- Cleaning products containing harmful substances
- Scourers
- The composition of your used products may not affect the structure or surface of the synthetic parts. Moreover, the epoxy coating may not be affected as well.

Always read the product information and follow the directions of the cleaning products and disinfectants.

### 4.2.2 Disinfection

A good chemical disinfection of the bed can only be obtained by cleaning the bed thoroughly. Always disinfect the bed before a new patient is put in the bed. Take the clinical picture of the patient and the potential presence of infected bed parts into account, and adjust the number of disinfections accordingly. Only qualified and trained personnel, familiar with the use of disinfectants, are allowed to disinfect the bed. Always wear appropriate working clothes, since disinfectants may cause irritations. Always follow the directions of the used product.

- Always use cold or tepid water to dilute the product. Do not use warm water, as this causes vapour. Always seal the dilution.
- Do not use alcoholic products to disinfect large surfaces.
- Avoid skin contact and always wear gloves.
- Always check if the correct quantity has been used.
- Always make sure that there is enough ventilation during and/or after the disinfection.
- Always use a cloth or a rag to disinfect. Do not use spray products (risk of inhalation!).

We would like to refer to the website of the Robert-Koch-Institut ([www.rki.de](http://www.rki.de)) to choose the correct disinfectant. Keep a disinfection journal for each bed and note down when and why the disinfection has taken place. Also write down which disinfectant and which quantity has been used, and do not forget to mention the name and signature of the cleaning person.

# TECHNICAL MANUAL

## V. GENERAL TECHNICAL DESCRIPTION

The design of this nursing bed is the answer to the demand of the health care sector for a bed providing optimal qualities in the fields of functionality, aesthetics and maintenance. The Olympia Care bed is a multifunctional, height-adjustable bed that maximizes both the comfort of the patient and the user-friendliness.

All steel elements are protected by an epoxy coating or a chromium-plated layer, whereas the hinge points have self-lubricating synthetic bearings (= maintenance-free). Rough surfaces, sharp corners and edges which may cause injuries or damage have been avoided or covered.

A well and preventively maintained bed that is used in accordance with the specifications of this manual can be used for 10 to 25 years (or at least 10,000 cycles per bed function) without any problems. An incorrect or very intensive use of the bed affects its lifespan very negatively. The same goes for bad preventive or curative maintenance. While maintaining the bed curatively or preventively, the technician always has to check if the bed still guarantees the basic safety of the patient or its user. If this is not the case anymore, the bed has to be put out of use.

Do not modify the bed without the explicit permission of Haelvoet NV. After a permitted modification, the bed always has to be inspected correctly. Furthermore, the bed has to be submitted to a thorough test to make sure that the bed still functions safely.

### **Recommended mattress dimensions:**

Mattress platform : 86 x 200 cm

Mattress dimensions (standard width): 85 cm x 195 cm

Mattress dimensions (width 90 cm): 89 cm x 195 cm

Minimum mattress thickness: 12 cm

Maximum mattress thickness, depending on the used sideguards type:

Pollux: 14 cm

Atmosphere: 14 cm

Atmosphere heightened : 22 cm

Trix: 16 cm

Minimum stiffness of the foam: 2,8 kPa in accordance with ISO 3386 (CLD/40%)

Always use a mattress made of fire retardant material.

In case visco-elastic foam is used, a supportive layer of minimum 7 cm with a minimum stiffness of 3,6 kPa in accordance with ISO 3386 (CLD/40%) has to be used.



**If the customer has ordered a specific mattress platform dimension, then the mattress dimensions have to be adjusted accordingly.**

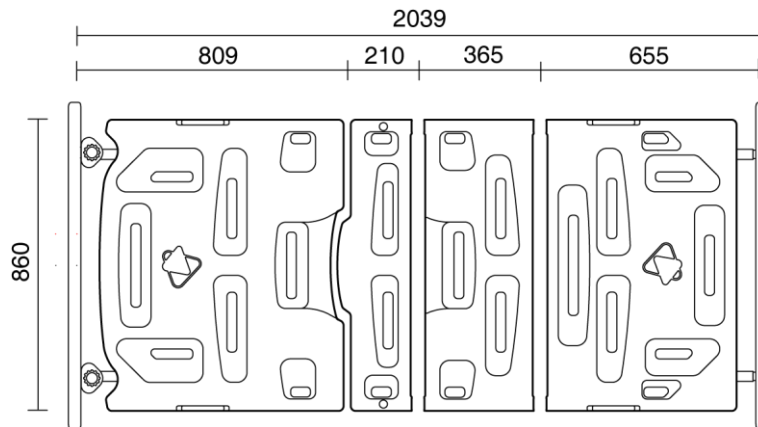

Figure 5.1: Mattress platform dimensions Olympia Care bed (standard width)

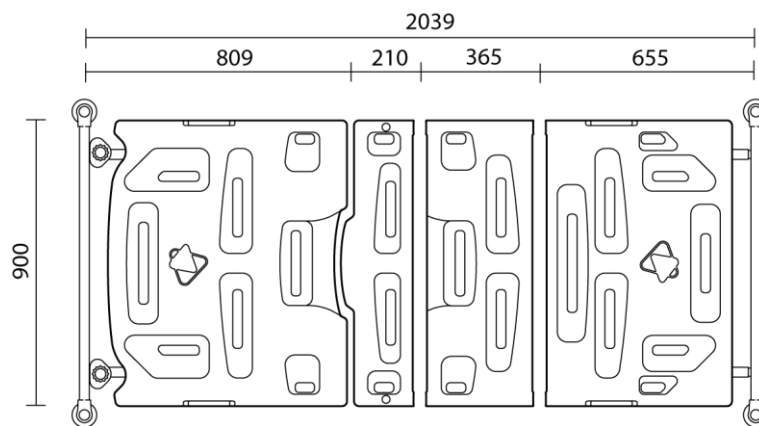

Figure 5.2: Mattress platform dimensions Olympia Care bed (width 90 cm)

<b>Castor Version:</b>	<b>H in mm</b>	<b>OL in mm*</b>	<b>OR in mm*</b>
Levina Ø125 (standard)	360 – 785 mm	167 mm	134 mm
Integral S Ø150	405 – 805 mm	187 mm	154 mm
Hidden twin castors Ø50mm	352 – 777 mm	159 mm	126 mm

\* OL : left side of the bed

\* OR : right side of the bed, reduced height for the central brake system

<b>Panel Version (standard width)</b>	<b>L in mm</b>	<b>BP in mm</b>	<b>P in mm</b>
Midea (standard)	2071 mm	1005 mm	399 mm
Felina/Valentino/Puro	2078 mm	1004 mm	426 mm

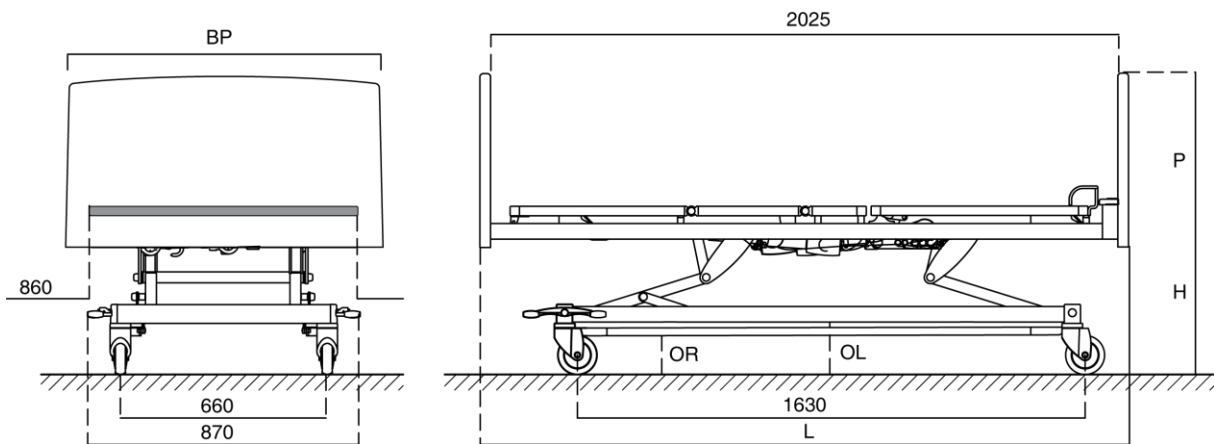

Figure 5.3: Dimensions of the Olympia Care bed (standard width)

**Castor Version:**

	H in mm	OL in mm*	OR in mm*
Levina Ø125 (standard)	360 – 785 mm	167 mm	134 mm
Integral S Ø150	405 – 805 mm	187 mm	154 mm
Hidden twin castors Ø50mm	352 – 777 mm	159 mm	126 mm

\* OL : left side of the bed

\* OR : right side of the bed, reduced height for the central brake system

**Panel Version (width 90 cm)**

	L in mm	BP in mm	P in mm
Midea (standard)	2071 mm	1045 mm	399 mm
Felina/Valentino/Puro	2078 mm	1045 mm	426 mm

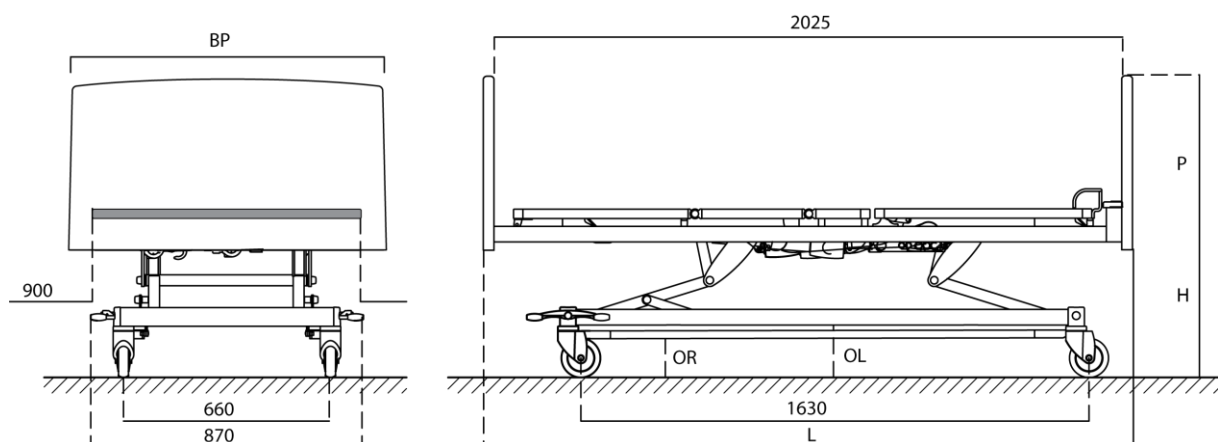

Figure 5.4: Dimensions of the Olympia Care bed (width 90 cm)

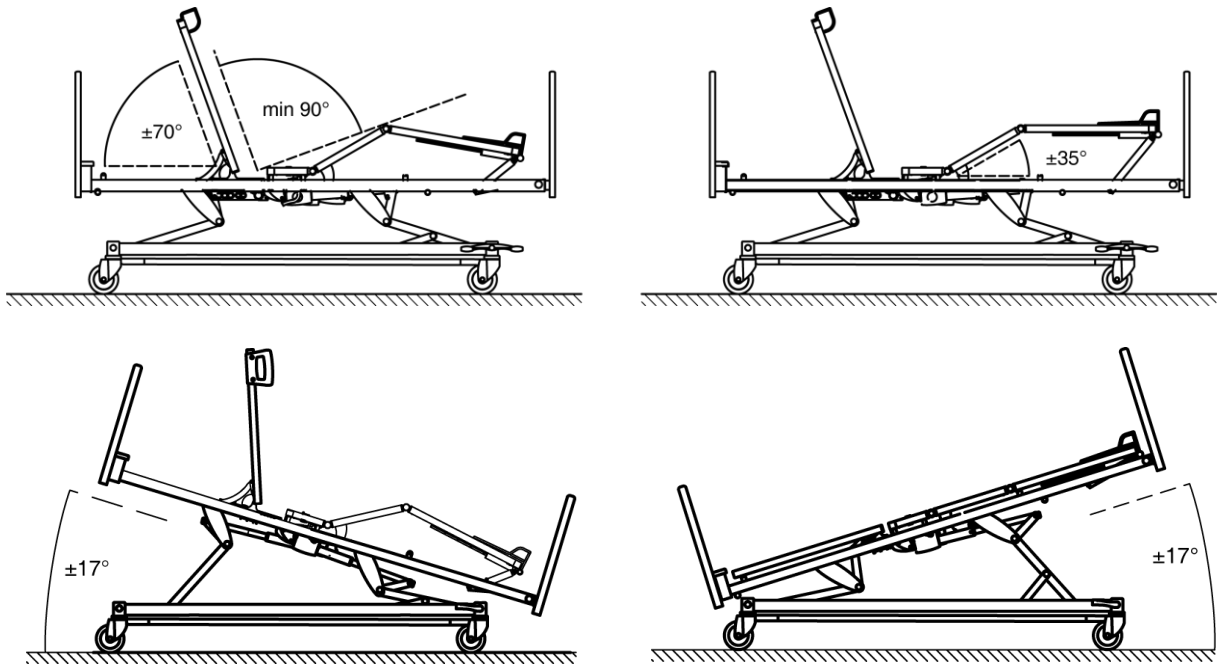

Figure 5.5: Most important manipulation data of the Olympia Care bed



## VI. ELECTRIC TECHNICAL DATA

### 6.1 Control box

Type	CB 06
Manufacturer	LINAK
Country of production	Denmark
Degree of protection	IPX6
Primary power supply / max. current intensity	230 VAC / 1,25 A
Frequency	50 Hz
Secondary power supply	24 VDC
Duty cycle	Max. 10 % or 2 min/18 min
Mains cable length	3 m
Plug type	Moulded two-pin Euro plug

The control box generates a direct current of 24V by means of a transformer. This direct current of 24 V drives the actuators and is not dangerous for the patient and its user.

The control box may only be connected to the mains, as mentioned on the control box label.

### 6.2 Hand switch

Type	HB 8X
Manufacturer	LINAK
Country of production	Denmark
Degree of protection	IPX6
Max. current intensity	30 mA

### 6.3 Hand switch HD

Type	HD 8X
Manufacturer	LINAK
Country of production	Denmark
Degree of protection	IPX6
Max. current intensity	30 mA

### 6.4 Satellite control

Type	FPP
Manufacturer	LINAK
Country of production	Denmark
Degree of protection	IPX6
Max. current intensity	5 mA

## 6.5 Control panel

Type	ACC (mini nurse box) or ACL (lock box)
Manufacturer	LINAK
Country of production	Denmark
Degree of protection	IPX4
Max. current intensity	100 mA

## 6.6 Battery

Type	Closed lead-acid battery
Manufacturer	LINAK
Country of production	Denmark
Input/output voltage	24 VDC
Minimum charge duration (empty)	12 to 16 hours
Capacity	1,2 Ah
Max. storage duration (not connected to the control box)	3 months without recharging
Max. connection duration (to the control box without recharging)	Advisable to connect the battery to the net at all times

## 6.7 Backrest actuator

Type	LA 27C
Manufacturer	LINAK
Country of production	Denmark
Degree of protection	IPX4
Input voltage	24 VDC
Length of stroke	200 mm
Speed	7 - 11 mm/s
Sound level	Max. 45 dB(A) DS/EN ISO 3746
Duty cycle	Max. 10 % or 2 min/18 min
Thrust	3500 N
Including	Quick release (optional), clamp safety

## 6.8 Knee rest actuator

Type	LA 27C
Manufacturer	LINAK
Country of production	Denmark
Degree of protection	IPX4
Input voltage	24 VDC
Length of stroke	60 mm
Speed	3.6 - 6 mm/s
Sound level	Max. 45 dB(A) DS/EN ISO 3746
Duty cycle	Max. 10 % or 2 min/18 min
Thrust	6000 N

Including

Clamp safety

## 6.9 High-low actuators

Type	LA 27C1
Manufacturer	LINAK
Country of production	Denmark
Degree of protection	IPX4
Input voltage	24 VDC
Length of stroke	146 mm
Speed	3.6 – 6 mm/sec
Sound level	Max. 45 dB(A) DS/EN ISO 3746
Duty cycle	Max. 10 % or 2 min/18 min
Thrust	6.000 N
Including	Clamp safety

## 6.10 Ambient conditions for the actuators

Temperature:	5°C tot 40°C
Relative humidity:	20 % to 90 % at 30°C without condensation (for IP X4)
Atmospheric pressure:	700 to 1060 hPa

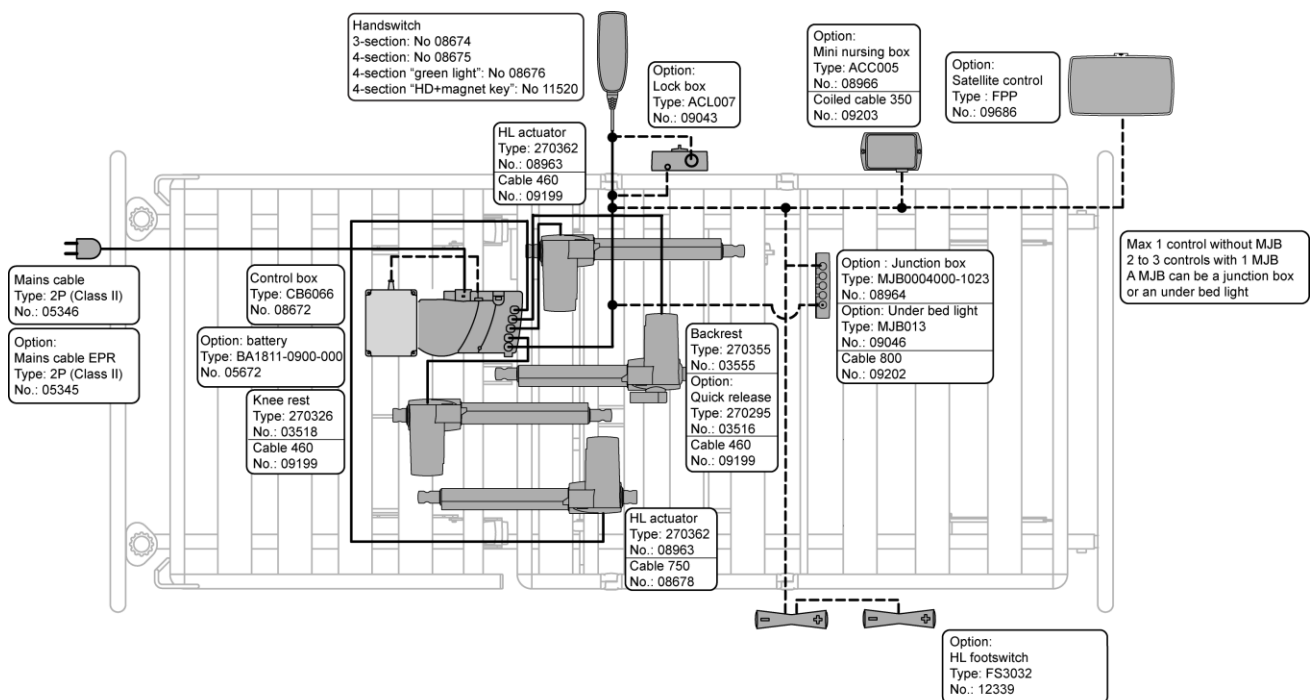

Figure 6.1: Circuit diagram Olympia Care

## 6.11 General specifications of the CB 06 control box

### a. Short circuit check

The CB06 control box is equipped with a safety device that indicates the 'first error'. This 'first error' is checked by the hardware of the control box.

When functioning properly (no error has been detected), the power LED turns yellow when a control button is activated.

If the power LED turns yellow without having activated a control button, this means that an error has occurred. (1<sup>st</sup> error)

The control box can function without any problem, even when the power LED is yellow *before* a control button is activated. However, the '1<sup>st</sup> error' still is present and has to be removed to prevent that this causes a dangerous situation.

### b. Energy-saving standby mode

A few seconds after a manipulation, the control box is set in an energy-saving standby mode. As soon as a function has been manipulated, the control box is activated automatically. The energy consumption of the standby mode is 0.3W

### c. Internal protection of the control box

The control box is internally protected by a safety fuse.

At the customer's request, the bed can be delivered with the corresponding electric parameters that are statutory in the respective country (Voltage, mains cable plug).

## 6.12 Precautions for cable connections



**Never install/remove a cable or actuator when the control box is connected to the net and/or a bed function has been activated.**

The following procedure has to be followed when replacing a cable or an actuator:

1. disconnect the bed from the net and wait for 5 seconds.
2. remove/install the necessary cables and/or actuator.
3. check if all cable fittings have been equipped with a rubber O-ring. Install the cables and fasten them by means of the appropriate lock mechanism.
4. connect the bed with the net and test its functionality.

Ignoring this procedure can result in a damaged control box.

Connections that are not used have to be closed with the correct cover to guarantee the mentioned IP-degree.

## VII. MECHANICAL TECHNICAL DATA

Bed type	Olympia Care
Weight of an empty bed without options	125 kg
Degree of protection	IP X4
Safe working load	230 kg*
Maximum patient weight	195 kg*
Max. load on the backrest	80 kg
Max. sound level during a manipulation	max 50dB(A)

\* It should be taken into consideration that the safe working load can only be realised, if the bed is loaded as mentioned in the norm EN 60601-2-52 (i.e. backrest 45 %, fixed section 25 %, knee rest and footrest 30 %). The bed may never be overloaded dynamically, in case all lifting power is concentrated at one bed end. In this way, the bed is protected against structural deformation. This lifting capacity applies to a bed load, with a patient in it, and with accessories, mattress and options.

## VIII. TECHNICAL DATA CASTORS

Type	Levina Ø 125 mm separately braked (standard)		Integral S Ø 150 mm central brake (option)	Twin castor Ø 50 mm central brake (hidden castors, option)	
Manufacturer	Tente		Tente	Steinco	
Country of production	Germany		Germany	Germany	
Castor diameter	125 mm		150 mm	50mm	
Castor width	32 mm		32 mm	2 x 19.5mm	
Bearing	Precision ball bearings		Precision ball bearings	Plain bearing	
Dynamic load capacity	100 kg		150 kg	100 kg	
Static load capacity	200 kg		300 kg	200 kg	
Load	500 N	1000 N	1350 N	500 N	1000 N
Swivelling resistance	27 N	75 N	60 N	34 N	72 N
Rolling resistance	6 N	15 N	10 N	11 N	23 N
Tread	Polyurethane		Polyurethane	Polyurethane	
Operating angle of the central brake			35°	35°	

## IX. STORAGE OF THE BED

Before storing the bed, you have to make sure that:

- the bed and the mattress platform sections have been put in their lowest position.
- the 4 brakes have been activated.
- all electric functions have been switched off.
- all accessories have been removed.
- ***the optional battery has to be charged every week or disconnected from the control box, in case the bed with a battery connected to the control box, is stored for more than one week.***
- the bed has been covered.
- the storage space is dry and dust-proof (relative humidity of 20 to 90% without condensation).
- the temperature remains relatively constant and lies between -10 and +50°.
- the atmospheric pressure lies between 700 hPa and 1060 hPa



**You have to check all functions before you want to use the bed again (see checklist in appendix).**

## X. PREVENTIVE AND CURATIVE MAINTENANCE

### 10.1 Safety responsibility

It is the responsibility of the institute to make sure that the bed guarantees the patient's safety during its entire life span. For this reason, the safety of the bed has to be checked regularly. Moreover, the bed has to be maintained preventively. The bed has been developed in such a way that it can be used safely for many years, on the condition that it is manipulated correctly and checked regularly. It also has to get at least one preventive maintenance a year.

It is the nurses' task to perform a routine check at regular times, especially when a new patient has to be put in the bed.



**The maintenance of the bed may only be carried out by qualified and technically trained personnel. The guarantee is nullified, if the maintenance of the bed has been carried out unprofessionally and causes damage to the bed functions.**



**All repairs to actuators, control boxes and actuator accessories have to be carried out by an authorised Linak service shop or by a technician that has been acknowledged by Linak. All guarantee conditions are nullified, if Linak parts have been opened. An acknowledged Linak technician can always obtain further information about Linak parts from Haelvoet or Linak.**



**Never perform maintenance work or repairs while the patient is still in the bed.**



**In order to optimize the life span of the bed and to avoid accidents, the European regulation obliges an annual preventive and registered maintenance. Use the checklist in appendix during this annual preventive maintenance. If necessary, consult this manual as well.**

The standard IEC EN 62353 - Medical electrical equipment - Recurrent test and test after repair of medical electrical equipment - can be used as a guide for a good maintenance procedure.

In addition to the annual registered preventive maintenance, we strongly recommend you to check the following items regularly:

- All electric functions.
- All mechanical functions (sideguards, castors,...).
- All cables and especially the mains cable.
- The hand switch and the connection cables
- Always check the mains cable when the bed has been moved and before connecting it to the net again.

When you think that there is some damage or that the bed does not function properly, you have to stop using the bed immediately. You also have to indicate clearly on the bed that it is OUT OF USE. Contact the person who is in charge of the beds as soon as possible.

The checklist in appendix can serve as a guideline during controls.

## 10.2 Preventive maintenance Trix and Pollux

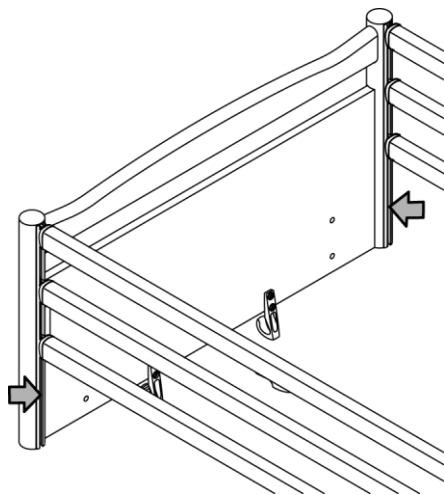

Grease the posts of the Trix and Pollux sideguards annually with 'ZEP45' or an equivalent to reduce internal wear. Please do not use a product with a base of silicone, because this dries.

**Figure 10.1: Greasing sideguards Trix and Pollux**

When used normally (i.e. an average of 2 cycles a day), it is advised to replace the clamps and the lock pin every 10 years. When used intensely (i.e. on average more than 2 cycles a day), the clamps and lock pin have to be replaced every 5 years. The procedure hereunder has to be followed:

### Sideguards Trix

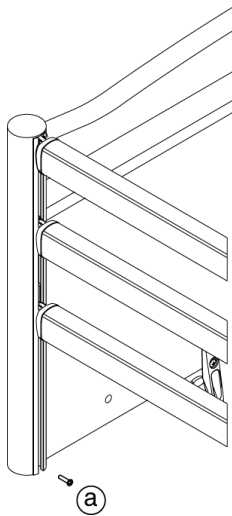

Unscrew the lock screw (a). Carefully lower and remove the siderails from the posts. Replace the clamps and locking pins.

**Figure 10.2: Maintenance sideguards Trix(1)**

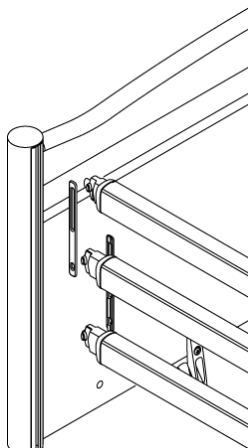

Put the aluminium profiles and the new synthetic clamps in the aluminium posts.

**Figure 10.3: Maintenance sideguards Trix(2)**



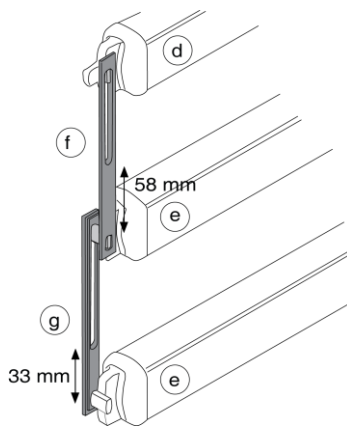

Please pay attention to the right assembly order:

- b) upper profile: guiding plug in front with an extending pin and suspension pin on one side
- c) middle profile: and profile at the bottom: guiding plug with a suspension pin on both sides
- d) upper clamp: solid piece of 58mm.
- e) bottom clamp: solid piece of 33 mm.

**Figure 10.4: Maintenance sideguards Trix(3)**

Reassemble the lock screw and check its functionality.

Sideguards Pollux :

Disassemble/assemble the sideguards in accordance with the descriptions in ‘3.1.2 Type Pollux extended’.



**A thorough preventive maintenance of the sideguards is of paramount importance to guarantee the patient’s safety.**

### 10.3 Spare parts

Haelvoet NV can provide all necessary spare parts. All you have to do, is to specify the article number, the sales order number and the serial number of the respective product. This information can be read on the identification label. This label is to be found on the side beam of the bed frame at the head end.



In order to keep the right to the guarantee, you are only allowed to use original Haelvoet NV parts. This instruction also applies to further maintain the safety of the bed! Do not hesitate to contact Haelvoet NV if you have specific questions or if you want to order spare parts:

**Haelvoet nv**  
**Leon Bekaertstraat 8**  
**8870 Ingelmunster**  
**Belgium**  
**Tel: +32 (0) 51 48 66 95**  
**Fax: +32 (0) 51 48 73 19**  
**Email: [info@haelvoet.com](mailto:info@haelvoet.com)**  
**[www.haelvoet.com](http://www.haelvoet.com)**

## 10.4 Used fastening methods

- axle retaining ring: This ring is used to fasten the mattress platform actuators and the metal parts. It can be easily removed by just pulling the clip. The axle can be locked again by pushing the retaining ring back in the groove.

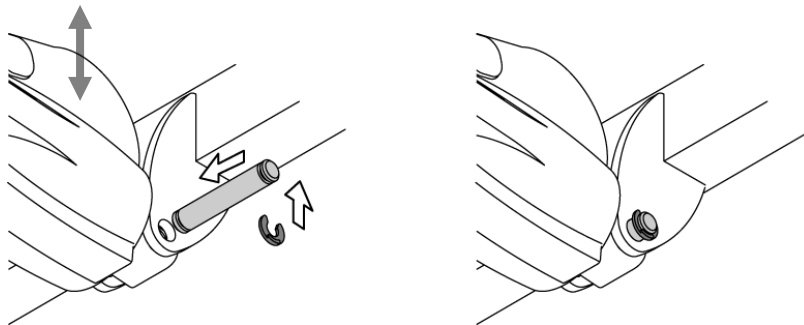

Figure 10.5: Axle and axle retaining ring

- cable clamp: All cables are fastened by means of clamps that can be removed and locked without needing any tools.

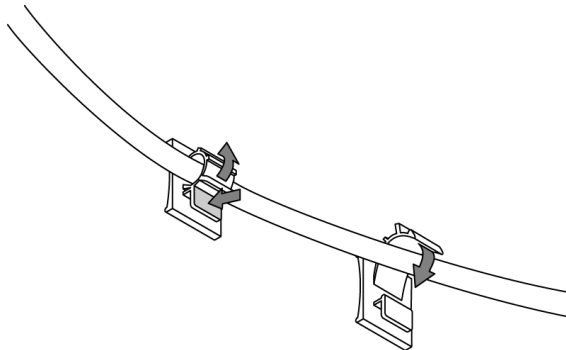

Figure 10.6: Cable clamp

## 10.5 Replacement of a high/low actuator

1. It is advisable to check if the actuator you have to replace is really damaged. This is possible by plugging a new actuator in the control box without actually building it in, and checking its functions.
2. Put the bed in a position, as high as possible.
3. Support the mattress platform at the head and foot end so that it cannot fall.
4. Disconnect the actuator cable from the actuator. It is advisable to check if the actuator you have to replace is really damaged. This is possible by plugging a new actuator in the control box without actually building it in, and checking its functions.
5. First remove the axle at the side of the carriage. Do not forget to support the actuator so that it cannot swivel downwards. After this, the second axle near the suspension point can be removed, making it possible to remove the actuator from the bed.

The opposite working method has to be followed to install an actuator in the bed.

## 10.6 Replacement of a mattress platform actuator

1. Disconnect the bed from the net.
2. Remove the load (e.g. mattress) from the mattress platform that exerts pressure on the actuator.
3. Disconnect the actuator from the control box. It is advisable to check whether the actuator is really damaged. This is possible by plugging a new actuator in the control box without actually building it in, and checking its functions.
4. First, you have to get the bar that activates the mechanical quick release (CPR) out of the quick release (optional), before you remove the backrest actuator. This can be done by removing the cover of this mechanism.
5. Open all cable clamps and remove the axle retaining ring from both axles.
6. First remove the axle on the side of the moving mattress platform section, but make sure that the moving mattress platform section and/or the actuator cannot come loose and/or fall. Afterwards, the second axle can also be removed, making it possible to take the actuator out of the bed.

The opposite working method has to be followed to install an actuator into the bed.



When you want to put back a removed actuator cable in the actuator or the control box, you always have to make sure that this happens correctly. Always plug in the cable as deep as possible and fasten the protective cap again. This is necessary to guarantee a reliable sealing and functioning. Always make sure that the cables are fastened in such a way that they cannot be damaged (no loops, kinks or incisions).



Only persons that have been acknowledged by Linak are allowed to open and repair an actuator. Always replace the entire electric part without opening it. Only a qualified technician is allowed to replace an actuator.

## 10.7 Readjustment of the CPR lever (optional)

1. Put the backrest in a horizontal position.
2. The nut on the thread end has to be adjusted in such a way that the lever doesn't have any clearance. Do not pull the lever too tight, because this can trigger an unforeseen activation of the lever without any manipulation.
3. Put the backrest in an inclined position and check if the quick release functions properly when there is a person in the bed.



Figure 10.7: Quick release mechanism

## 10.8 Battery (optional)

### Technical specifications:

*Type:* closed lead-acid battery with a capacity of 1,2 Ah

*Life span at normal use:* minimum 3 years. The way of use can shorten this life span considerably.

*Operating time:* depending on the kind of movement (HL, back or knee rest) and load. A height variation requires the largest amount of current (2 parallel actuators). 6 to 10 complete high/low cycles can be carried out when there is a load of 130 kg. Obviously, a lot more manipulations are possible for a backrest and knee rest adjustment. An alarm signal warns you during an electric manipulation, in case the capacity of the battery does not suffice anymore to manipulate the bed. Immediately connect the bed to the net as soon as this alarm signal is audible.

Charge the battery completely before you start using the bed (at least 12 hours). Multiple high discharges have a harmful effect on the life span of the battery.

### Description:

Linak uses *closed lead-acid batteries*. Given its long-time experience in using this type of battery, Linak considers the closed lead-acid battery as the safest battery available at the moment. To prevent potential problems, we strongly recommend you to follow the maintenance advice as described hereunder:

- The battery sets have an life span of minimum 3 years. Frequent discharges have a harmful effect on the life span of the battery. It is recommended to connect the control box as much as possible to the net, so that a long life span of the battery is guaranteed. It is also necessary to charge a battery that is not built-in, and not used, at least every 3 months. In this way, you prevent a self-discharge of the battery.
- The battery has to be replaced every 5 years, irrespective of the operating conditions. Using the battery longer can damage the controlbox and/or the battery.
- The sintered plug in the ventilation opening has to be replaced or pricked once a year to prevent that it gets clogged with dirt, lime or other substances. This plug can be easily removed by means of a screw. Furthermore, the ventilation opening can be cleared by using a spill of Ø 1 mm.
- Replaced batteries go via Linak or Haelvoet to the recycling cycle, or may be recycled in the same way as car batteries.

### Annual preventive battery check:

Make sure that the battery is completely charged before it is tested. Disconnect the bed from the net and put a weight of about 75 kg on the mattress. The battery should be able to carry out at least two complete high/low cycles without any problems. If this is not the case, it is advised to replace the battery immediately.



The ventilation opening may not be covered! If you do this, you increase the risk of battery explosion!



If there has been a big impact on the battery (e.g. falling on the ground), you have to disconnect the external battery from the control box and replace it.



Always replace a battery that is older than 5 years or of which the capacity is too low. Faulty or old batteries increase the risk of explosion.

## 10.9 Replacement of the mains cable

If the mains cable is damaged, you have to replace it immediately. Follow the instructions described hereunder to replace the mains cable correctly:

1. Disconnect the plug from the net.
2. Release the strain relief. The strain relief is situated at the head end, underneath the backrest. The bed can be equipped with two different types of strain relief:

### Strain relief type 1

Unscrew the metal nut and remove the mains cable from the fixing groove.

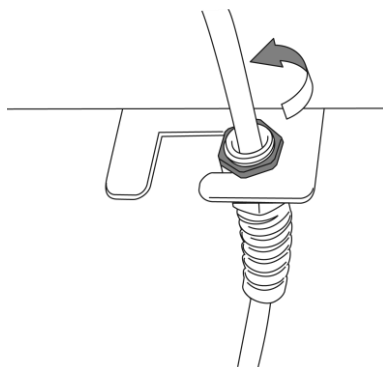

**Figure 10.8: Release of the strain relief type 1**

### Strain relief type 2

Unscrew both screws from the synthetic strain relief and loosen the upper part. The mains cable can be removed now.

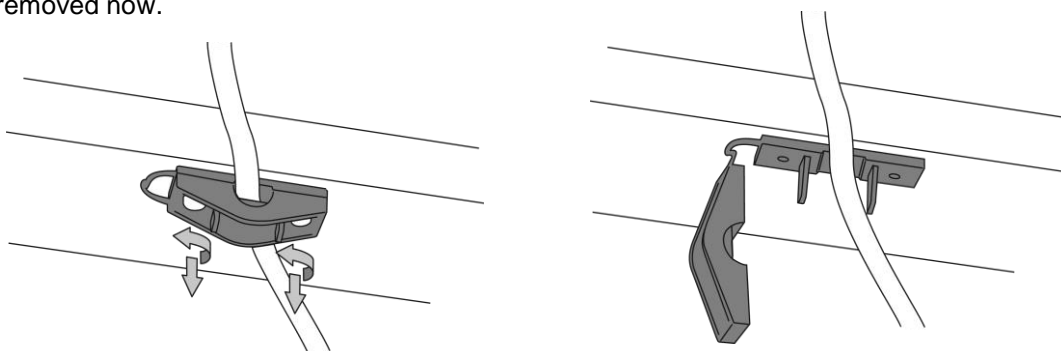

**Figure 10.9: Release of the strain relief type 2**

3. Disconnect the mains cable from the control box. To do this, you have to push in two red pins, while pulling the plug out of the control box. A flat screwdriver is the best tool to push in these red pins. To install the mains cable, you have to push in both pins while you plug in to the control box. Make sure that both pins are anchored properly in the control box. You can check this by pulling the plug.

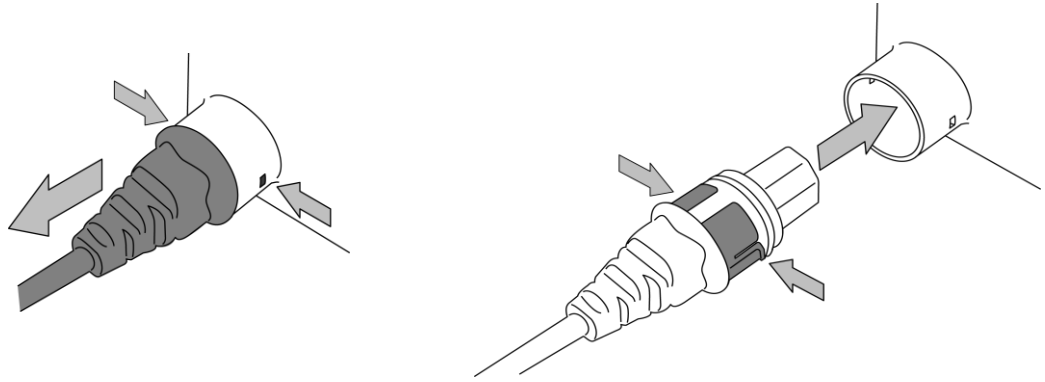

**Figure 10.10: Replacement of the mains cable in the control box**

4. Install the strain relief again. Make sure that the strain relief is fixed properly and not damaged. The strain relief has an extremely important function: it avoids traction on the control box in case the mains cable is used incorrectly.

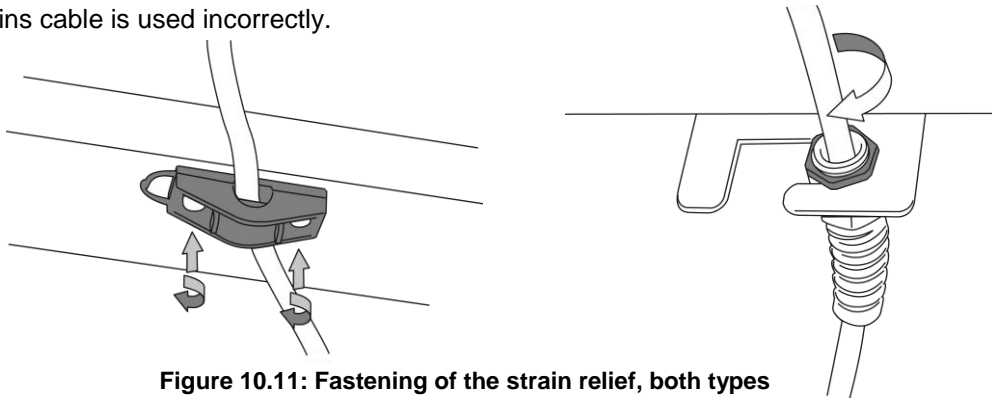

**Figure 10.11: Fastening of the strain relief, both types**

## 10.10 Replacement of a control box

Disconnect the control box CB06S from the net. Unplug the control box. Remove the control box from its support plate. Install a new control box and connect all plugs again (see circuit diagram, figure 6.2).

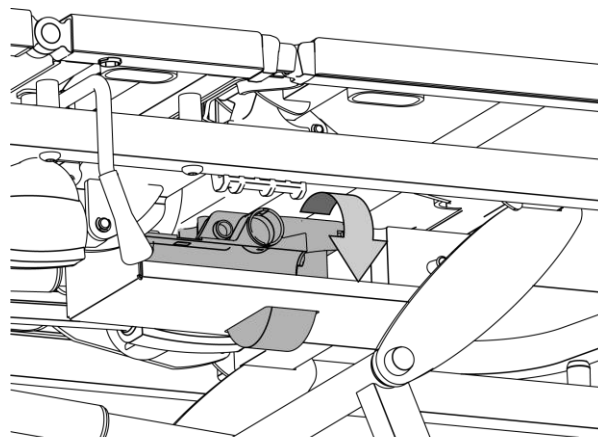

**Figure 10.12: How to replace the control box**

## **XI. POSSIBLE PROBLEMS**

### **Problem 1: The bed is acting slower than normal.**

#### **Is the bed connected to the (electricity) net?**

- No -> The bed is functioning on its battery, which is slowing down the functions.
- Yes -> Please check if the bed is not too much charged/loaded (too much weight on the bed)?

#### **Is overload the cause of reducing the speed of the operations ?**

- Yes -> Please lower the charge/ the load of the bed and don't use the bed for a couple of hours.
- No -> Please check the voltage of the net.

### **Problem 2: Not all functions of the bed are working.**

#### **Are some functions on the nurse box not blocked?**

- Yes-> Please unlock the blocked functions on the nurse box.

#### **Are the lights on the nurse box not flashing ?**

- Yes-> Please implement the reset procedure. (please ask for reset procedure document)
- No-> Please check if all cables are well plugged in, as well as please check the condition of the cable of the actuator that is not functioning. In the worse case a new cable have to be installed.

#### **Is the problem solved?**

- No-> Please connect a new actuator onto the control box and check it's functioning with the hand control.

#### **Is the problem solved?**

- Yes-> Install the new actuator on the bed.
- No-> Replace the hand control or the nurse box.

### **Problem 3: One of the hand control units are not working.**

**Please check if the hand controls are well plugged in as well as check the condition/ the functioning of their cables. Move the cable when activating a function of the hand control. If needed replace the hand control unit.**

### **Problem 4: no functions are working at all.**

#### **Is the bed connected to the net?**

- No-> The battery is completely empty. Please connect the bed to the net

#### **Is the green light of the control box lighting up?**

- Yes-> Please check if the functions are not blocked on the nursing box (ACO box) or check the hand control.
- No-> Check the condition of the feeding cable (in between net & control box) as well as check the voltage of the net.

**\*Reset: see Fig 2.12**

## XII. ACCESSORIES

Only the following accessories that have been acknowledged by Haelvoet can be used for the bed. If you use other accessories, Haelvoet NV cannot be held liable for any possible accident, malfunction or damage.

Id.nr.    Accessory :

00441	Flexible hand switch holder
01840	Lifting pole
01856	IV rod
01863	Document holder A4 (horizontal)
01864	Document holder A4 (vertical)
03576	Document holder A3 (horizontal)
02755	Dinner tray to put onto the sideguards
03296	Urine bottle holder (vertical) (only if the bed is equipped with accessory hooks)
10625	Urine bottle holder (horizontal) (only if the bed is equipped with accessory hooks)
05878	Bowl holder (only if the bed has been equipped with accessory hooks)
06366	Oxygen bottle holder
07180	Raising aid
08004	IV rod to attach to the lifting pole
09242	Bed pan hook
09629	Accessory brace (only if the bed is equipped with accessory hooks)
09945	Removable mattress platform extension



When using the high/low function, the backrest or knee rest, you have to make sure that the patient does not get stuck because of accessories. If this cannot be guaranteed, then the nurse has to prevent that the patient can use the high/low function, the backrest and knee rest.

This can be done by placing the hand switch outside the reach of the patient (e.g. at the foot end of the bed), or by blocking these functions (by means of the lock box)



### **XIII. GUARANTEE**

The contractual guarantee is nullified, if spare parts are used that are not permitted, or if non-authorized interventions or actions are performed, such as:

- Opening an actuator, control box, hand switch, battery or any other electric or electronic part.
- Cleaning of an IPx4 bed in a wash tunnel or cleaning with unauthorized products.
- Incorrect use or incorrect assembly.
- Activations that conflict with the instructions in this manual.
- Activations that exceed the expectations of a standard hospital bed.

**The stipulated guarantee period in the contract is only valid when an annual and ‘registered’ preventive check is performed on the bed.**

**Spare parts that are covered by the guarantee will not be invoiced, only when the faulty spare parts are returned.**

## XIV. RESIDUAL WASTE AND THE ENVIRONMENT

Please sort the residual waste in accordance with the regulatory environmental requirements. Replaced electric parts such as actuators, control boxes and hand switches have to be processed as electronic waste. If you decide not to use the bed any longer and to destroy it, then the bed has to be disassembled and recycled in accordance with the environmental legislation.

This product contains recyclable aluminium, steel, synthetic material and electronic components. In order to recycle optimally at the end of the bed's life span, all parts have to be separated in such a way that the basic materials of this product can be used again.

Haelvoet NV is fully aware of the fact that the environment has to be protected for the next generations. That is why we pay extra attention to development, innovation, production and the use of environment-friendly technologies and materials.



This logo wants to point out to the consumer that waste belongs in a dustbin and not in natural areas or on the public highway.



This symbol – known as the möbius loop – can mean two things: “Recyclable” product or “This product contains recycled material”. If the latter is the case, then the word ‘recycled’ has to be mentioned.

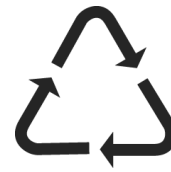

Recyclable synthetic material. A number refers to the sort of plastic that is used to make the product. For the moment, only plastic types 1, 2 and 3 can be recycled.

Plastic types:

- 1 = PET
- 2 = HDPE
- 3 = PVC
- 4 = LDPE
- 5 = PP
- 6 = PS
- 7 = other types

This product is made of environment-friendly materials! It does not contain any dangerous substances such as cadmium, mercury, asbestos, PCBs or CFCs. The sound level of the bed complies with the regulatory demands to protect the public health against unwanted noise and vibrations in a protective interior area.

This product has a lead-acid battery (in option). When the life span of the battery has come to an end, hand in this battery to a person or institute that is authorized for battery collection.

### **Information for the users of electric and electronic equipment.**



This symbol on the product or supplied documentation means that the used electric or electronic components (waste of electric and electronic equipment = OEEZ/WEEE) may not be given or destroyed with domestic waste. Only specialised firms are authorized to process this waste. These firms will accept your waste without charge.

By removing and recycling these components properly, you protect valuable natural resources. You also prevent possible negative effects on public health. Further information can be obtained from the governmental agencies that are officially acknowledged for the protection of the environment, or from the nearest assembly point for the collection of separated waste.



**If you don't follow the correct procedures for waste disposal, the national legislation can seriously fine you!**

### **Information about the disposal of electric and electronic equipment for users in countries outside the European Union:**

The symbol as showed above only applies for countries of the European Union. Please consult your local authorities or distributor for more information about the correct disposal of OEEZ/WEEE (waste of electric and electronic equipment) and lead-acid batteries.

**Protect your health and the environment.**

**Protecting the environment is protecting the future. Thank you.**

## XV. SYMBOLS



Backrest adjustment



High-low adjustment

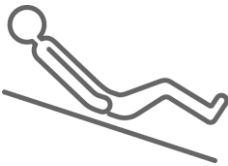

Relax/chair-adjustment



Block function

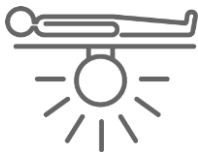

Nightlight under the bed



Warning

Not following this instruction can lead to accidents with serious injuries.



Not following this instruction can lead to material damage to the bed and/or surroundings.



Knee rest adjustment



Trend. – Reverse-Trend.

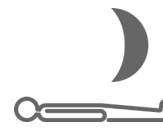

Sleeping function



Battery charge indicator



Magnetic key



Forbidden

## XVI. CONFORMITY

The Olympia Care bed is produced in accordance with ISO 9001:2008 and complies with the European Medical Devices directive 93/42/EEC and all applicable European harmonized norms:

**EN 60601-1** Medical electrical equipment - Part 1 : General requirements for basic safety and essential performance.

**EN 60601-1-2** Medical electrical equipment - Part 1-2 : General requirements for basic safety and essential performance - Collateral standard : Electromagnetic compatibility - Requirements and tests.

**EN 60601-2-52** Medical electrical equipment - Part 2-52: Particular requirements for basic safety and essential performance of medical beds.

**EN ISO 14971** Medical devices - Application of risk management to medical devices.

### 16.1 Explanation CE-label and Identification-label

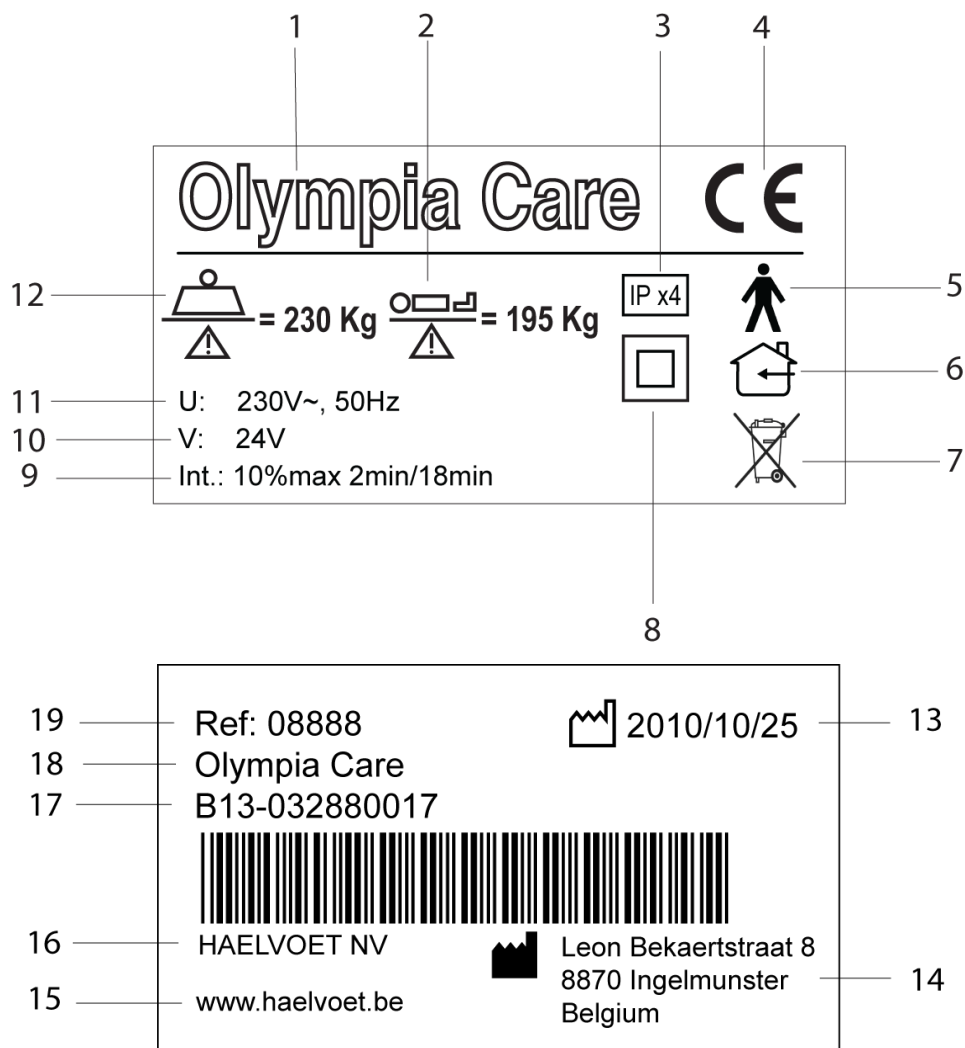

- |  |                                       |
|--|---------------------------------------|
| 1 Name Article   | 10 Max Input current                  |
| 2 Safe patient load  | 11 Input voltage                      |
| 3 Protection against splashing water coming from all directions                    | 12 Sage working load                  |
| 4 Conformity mark in accordance with the directive for medical equipment 93/42/EEC | 13 Date of manufacture                |
| 5 Type B equipment according to EN 60601-1   | 14 Address manufacturer               |
| 6 To be used indoors   | 15 Website manufacturer               |
| 7 Attention! Electronic waste  | 16 Manufacturer                       |
| 8 Class II equipment   | 17 Series number / Sales order number |
| 9 Move for a maximum of 2 minutes, then 18 minutes pause                           | 18 Name Article                       |
|  | 19 Article number                     |

## 16.2 Used symbols

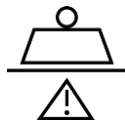

Safe working load

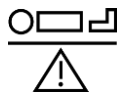

Safe patient weight



Type B equipment according to EN 60601-1



Protection against splashing water coming from all directions.



Class II equipment



To be used indoors



Thermal switch off in the transformer



Double-insulated transformer



Conformity mark in accordance with the directive for medical equipment 93/42 EEC



Obliged reading of the manual **before** using the bed



Consult the manual when using the bed



Warning



Incompatible mattresses can be dangerous, read the manual.

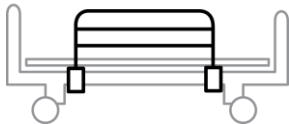

Incompatible sideguards can be dangerous, read the manual.



The used electric or electronic components may not be given or destroyed with domestic waste.



Direction of the head, obliged reading of the manual before using the bed

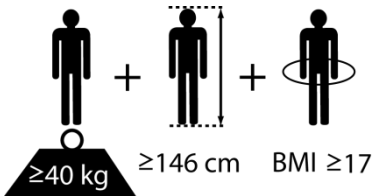

Physical description of an adult patient

## APPENDIX 1: EC-DECLARATION

### EC- DECLARATION OF CONFORMITY

Following the EC Directive concerning medical devices 93/42/EEC, annex VII.

I, the undersigned, agent of the following manufacturer:

**Haelvoet nv**

**Leon Bekaertstraat 8**

**8770 Ingelmunster**

**Belgium**

**Tel.: +32 (0) 51 48 66 95**

**Fax: +32 (0) 51 48 73 19**

**Email: [info@haelvoet.com](mailto:info@haelvoet.com)**

Declare hereby that the following product:

**Olympia Care**

**No.: 08888**

Medical device class I (non-invasive device)

when installed, maintained and used in accordance with the manual, the rules of good craftsmanship, and the intended purpose complies with all necessary safety requirements and other relevant provisions of annex I of:

#### **Medical Devices directive 93/42/EEC**

The following norms have been applied to indicate the conformity:

**EN 60601-1** Medical electrical equipment - Part 1 : General requirements for basic safety and essential performance.

**EN 60601-1-2** Medical electrical equipment - Part 1-2 : General requirements for basic safety and essential performance - Collateral standard : Electromagnetic compatibility - Requirements and tests.

**EN 60601-2-52** Medical electrical equipment - Part 2-52: Particular requirements for basic safety and essential performance of medical beds.

**EN ISO 14971** Medical devices - Application of risk management to medical devices.

The conformity to the mentioned harmonised norms is certified by:

**TÜV SÜD Product Service GmbH**

**Approval certificate Z1 15 02 84536 011**



The above-mentioned product has been designed, produced and checked in accordance with the quality management system of **ISO 9001:2008**.

**Ingelmunster, 16/04/2010**

**Signature:**

A handwritten signature in blue ink, appearing to read 'Vincent Haelvoet', enclosed in a blue oval.

**Haelvoet Vincent  
Managing director**



## APPENDIX 2: CHECKLIST MAINTENANCE

<b>Customer:</b>			
<b>Address:</b>			
<b>Performed:</b>	<input type="checkbox"/> check on delivery	<input type="checkbox"/> periodical check	
	<input type="checkbox"/> other	<input type="checkbox"/> check after repair or maintenance	
<b>Bed type:</b>	<input type="checkbox"/> Hospital bed	<input checked="" type="checkbox"/> Nursing bed	<input type="checkbox"/> Protection class: I <input type="checkbox"/> Protection class: II
<b>Model:</b>	Olympia Care	<b>Id nr.:</b>	
<b>Installation:</b>			
<b>Manufacturer:</b>	Haelvoet nv		
<b>Class:</b>	Class I Medical Device		
<b>I. Visual check</b>	<b>Good</b>	<b>Not good</b>	<b>Malfunction description</b>
<b>Visual check of the electric parts</b>			
Stickers and identification plates	Present		
Housing of the control box	Correct position, damage		
Housing of the actuators	Correct position, damage		
Battery	Age		
Fixation of the actuator shafts	All fastening clips are present		
Hand switch	Damage		
Actuator, hand switch supply cables	Damage, because the cable is jammed or cut/incised. Check the cable route and fixation		
All plug connections with the control box	Plugged in correctly, bayonet lock is present + installed correctly		
Strain relief of the supply cable	Supply cable is fastened properly		
Equipotential connections (optional)	Damage, fastened properly		
<b>Visual check of the mechanical parts</b>			
Stickers and identification plates	Present		
Carriage	Damage, deformation		
Castors	Damage		
Mattress platform sections	Damage, deformation		
Welded joints	Broken joint		
Sideguards	Damage, deformation, compliance with the statutory norm		
Wear-sensitive parts, such as hinge points	Wear, breakage		
All nuts/bolts			
Lifting pole	Damage, deformation		
Lifting pole handle	Damage, deformation		
Lifting pole ribbon	Damage (fraying)		
<b>II. Electric measurement in accordance with EN 62353</b>	<b>Good</b>	<b>Not good</b>	<b>Malfunction description</b>

III. Performance check		Good	Not good	Malfunction description
<b>Performance check of the electric parts</b>				
Performance of all actuators and control box	Test as instructed by the manual			
Sound of all actuators and control box				
Battery	Performance			
Hand switch	Functioning, sound, lock functions Position and functioning of the magnet of the HD-Hand switch (option)			
Lock box, locking mechanism	Test as instructed by the manual			
Limit switch on the actuators	Automatic			
High/Low foot pedal (optional)	Functioning			
Brake buzzer (optional)	Functioning			
<b>Performance check of the mechanical parts</b>				
Complete bed functionality				
Hinges and virtual pivot points	Smooth, fluent movement Lubrication with vaseline			
Castors	Brakes, unblocking			
CPR lever	Functioning as mentioned in this manual			
Sideguards	Functioning, blocking			
Bed and foot extension	Fluent functioning			
Footrest or legrest adjustment	Telescopic adjust functions properly			
Bumpers	Functioning			
Lock box	Functioning of the slide Length of the cable			
<b>Check results</b>				
<b>All check results are within the permitted limits</b>	<input type="checkbox"/> yes <input type="checkbox"/> no		<b>Next date of inspection:</b>	
<b>Successful check</b>	<input type="checkbox"/> yes <input type="checkbox"/> no			
<b>Unsuccessful check</b>	<input type="checkbox"/> Malfunction, do not use the bed! ⇒ repair <input type="checkbox"/> Malfunction, do not use the bed! ⇒ put the bed OUT OF USE <input type="checkbox"/> Bed does not comply with the safety norm			
<b>Test sticker is present</b>	<input type="checkbox"/> yes <input type="checkbox"/> no			
<b>Other remarks</b>				
<b>Comments</b>				
<b>Datum of inspection:</b>	<b>Inspector:</b>		<b>Signature:</b>	

### APPENDIX 3: EMC-TABLES

<b>Guidance and manufacturer’s declaration – electromagnetic emission</b>		
The Olympia Care bed is intended for use in the electromagnetic environment specified below. The customer or the user of the Olympia Care bed should assure that it is used in such an environment.		
Emissions test	Compliance	Electromagnetic environment - guidance
RF emissions CISPR 11	<b>Group 1</b>	The Olympia Care bed uses RF energy only for its internal function. Therefore, its RF emissions are very low and are not likely to cause any interference in nearby electronic equipment. The Olympia Care bed is suitable for use in all establishments, including domestic establishments and those directly connected to the public low-voltage power supply network that supplies buildings used for domestic purposes.
RF emissions CISPR 11	Class B	
Harmonic emissions IEC 61000-3-2	Class A	
Voltage fluctuations / flicker emissions IEC 61000-3-3	Complies	

## Guidance and manufacturer's declaration – electromagnetic immunity

The Olympia Care bed is intended for use in the electromagnetic environment specified below. The customer or the user of the Olympia Care bed should assure that it is used in such an environment.

Immunity test	IEC 60601 test level	Compliance level	Electromagnetic environment - guidance
Electrostatic discharge (ESD) IEC 61000-4-2	± 6 kV contact ± 8 kV air	± 6 kV contact ± 8 kV air	Floors should be wood, concrete or ceramic tile. If floors are covered with synthetic material, the relative humidity should be at least 30 %.
Electrostatic transient / burst IEC 61000-4-4	± 2 kV for power supply lines ± 1 kV for input/output lines	± 2 kV for power supply lines ± 1 kV for input/output lines	Mains power quality should be that of a typical commercial or hospital environment.
Surge IEC 61000-4-5	± 1 kV differential mode ± 2 kV common mode	± 1 kV differential mode ± 2 kV common mode	Mains power quality should be that of a typical commercial or hospital environment.
Voltage dips, short interruptions and voltage variations on power supply input lines IEC 61000-4-11	< 5 % $U_T$ (>95 % dip in $U_T$ ) for 0,5 cycle  40 % $U_T$ (60 % dip in $U_T$ ) for 5 cycles  70 % $U_T$ (30 % dip in $U_T$ ) for 25 cycles  < 5 % $U_T$ (>95 % dip in $U_T$ ) for 5 sec	< 5 % $U_T$ (>95 % dip in $U_T$ ) for 0,5 cycle  40 % $U_T$ (60 % dip in $U_T$ ) for 5 cycles  70 % $U_T$ (30 % dip in $U_T$ ) for 25 cycles  < 5 % $U_T$ (>95 % dip in $U_T$ ) for 5 sec	Mains power quality should be that of a typical commercial or hospital environment. If the user of the Olympia Care bed requires continued operation during power mains interruptions, it is recommended that the Olympia Care bed be powered from an uninterruptible power supply or a battery.
Power frequency (50/60 Hz) magnetic field IEC 61000-4-8	3 A/m	3 A/m	Power frequency magnetic fields should be at levels characteristic of a typical location in a typical commercial or hospital environment.

NOTE  $U_T$  is the a. c. mains voltage prior to application of the test level.

## Guidance and manufacturer's declaration – electromagnetic immunity

The Olympia Care bed is intended for use in the electromagnetic environment specified below. The customer or the user of the Olympia Care bed should assure that it is used in such an environment.

Immunity test	IEC 60601 test level	Compliance level	Electromagnetic environment - guidance
<p>Conducted RF</p> <p>IEC 61000-4-6</p>	<p>3 V</p>	<p>3 V</p>	<p>Portable and mobile RF communications equipment should be used no closer to any part of the Olympia Care bed, including cables, than the recommended separation distance calculated from the equation applicable to the frequency of the transmitter.</p> <p><b>Recommended separation distance</b></p> $d = \left[ \frac{3,5}{V_1} \right] \sqrt{P}$
<p>Radiated RF</p> <p>IEC 61000-4-3</p>	<p>3 V/m</p> <p>80 MHz to 2,5 GHz</p>	<p>3 V/m</p>	$d = \left[ \frac{3,5}{E_1} \right] \sqrt{P} \quad 80 \text{ MHz to } 800 \text{ MHz}$ $d = \left[ \frac{7}{E_1} \right] \sqrt{P} \quad 800 \text{ MHz to } 2,5 \text{ GHz}$ <p>where <math>p</math> is the maximum output power rating of the transmitter in watts (W) according to the transmitter manufacturer and <math>d</math> is the recommended separation distance in metres (m).<sup>b</sup></p> <p>Field strengths from fixed RF transmitters, as determined by an electromagnetic site survey,<sup>a</sup> should be less than the compliance level in each frequency range.<sup>b</sup></p> <p>Interference may occur in the vicinity of equipment marked with the following symbol:</p> <div style="text-align: center;">  </div>

NOTE 1 At 80 MHz and 800 MHz, the higher frequency range applies.

NOTE 2 These guidelines may not apply in all situations. Electromagnetic propagation is affected by absorption and reflection from structures, objects and people.

<sup>a</sup> Field strengths from fixed transmitters, such as base stations for radio (cellular/cordless) telephones and land mobile radios, amateur radio, AM and FM radio broadcast and TV broadcast cannot be predicted theoretically with accuracy. To assess the electromagnetic environment due to fixed RF transmitters, an electromagnetic site survey should be considered. If the measured field strength in the location in which the Olympia Care bed is used exceeds the applicable RF compliance level above, the Olympia Care bed should be observed to verify normal operation. If abnormal performance is observed, additional measures may be necessary, such as reorienting or relocating the Olympia Care bed.

<sup>b</sup> Over the frequency range 150 kHz to 80 MHz, field strengths should be less than 3 V/m.

## Recommended separation distances between portable and mobile RF communications equipment and the Olympia Care bed

The Olympia Care bed is intended for use in an electromagnetic environment in which radiated RF disturbances are controlled. The customer or the user of the Olympia Care bed can help prevent electromagnetic interference by maintaining a minimum distance between portable and mobile RF communications equipment (transmitters) and the Olympia Care bed as recommended below, according to the maximum output power of the communications equipment

Rated maximum output of transmitter  W	Separation distance according to frequency of transmitter m		
	150 kHz to 80 MHz  $d = \left[\frac{3,5}{V_1}\right]\sqrt{P}$	80 MHz to 800 MHz  $d = \left[\frac{3,5}{E_1}\right]\sqrt{P}$	800 MHz to 2,5 GHz  $d = \left[\frac{7}{E_1}\right]\sqrt{P}$
0,01	0,12	0,12	0,23
0,1	0,37	0,37	0,74
1	1,17	1,17	2,33
10	3,69	3,69	7,38
100	11,67	11,67	23,33

***For transmitters rated at a maximum output power not listed above the recommended separation distance  $d$  in metres (m) can be estimated using the equation applicable to the frequency of the transmitter, where  $P$  is the maximum output power rating of the transmitter in watts (W) according to the transmitter manufacturer.***

NOTE 1 At 80 MHz and 800 MHz, the separation distance for the higher frequency range applies.

NOTE 2 These guidelines may not apply in all situations. Electromagnetic propagation is affected by absorption and reflection from structures, objects and people.

## APPENDIX 4: TRAINING CERTIFICATE

# Training Certificate

### Customer & instructor specifications

Customer:	Company + Contact information.....	Training followed by.....
	.....	.....
Instructor:	Company + Contact information.....	Training given by.....
	.....	.....

### Product specifications

Product name + description	Article number:	.....
.....	Serial number:	.....
.....	Sales order number:	.....
.....	Delivery date:	.....

### Certificate of training

I hereby confirm that the user has received a training to become familiar with the use of this product.		
Remarks:		
.....		
.....		
.....		
.....		
Date:	Name + customer signature + stamp	Name + instructor signature + stamp
.....	.....	.....



Haelvoet NV | L. BEKAERTSTRAAT 8, 8770 INGELMUNSTER, BELGIUM | T +32 (0) 51 48 66 95 | F +32 (0) 51 48 73 19 | INFO@HAELVOET.BE | WWW.HAELVOET.BE

Written by:

Haelvoet NV  
Leon Bekaertstraat 8  
8770 Ingelmunster  
Belgium

Tel. +32 51 48 66 95  
Fax. +32 51 48 73 19

[info@haelvoet.com](mailto:info@haelvoet.com)  
[www.haelvoet.com](http://www.haelvoet.com)



All rights reserved. Nothing from these operating instructions and technical manual may be reproduced without the prior written consent of Haelvoet NV.